

Ohio River Trail Council

Bicycle Friendly Community Initiative



BIKE RACK PROGRAM

- Bike Rack Planning
- Type of Bike Rack
- On-street Bike Parking
- Bike Rack Installation

Dr. Vincent Traia, CEO

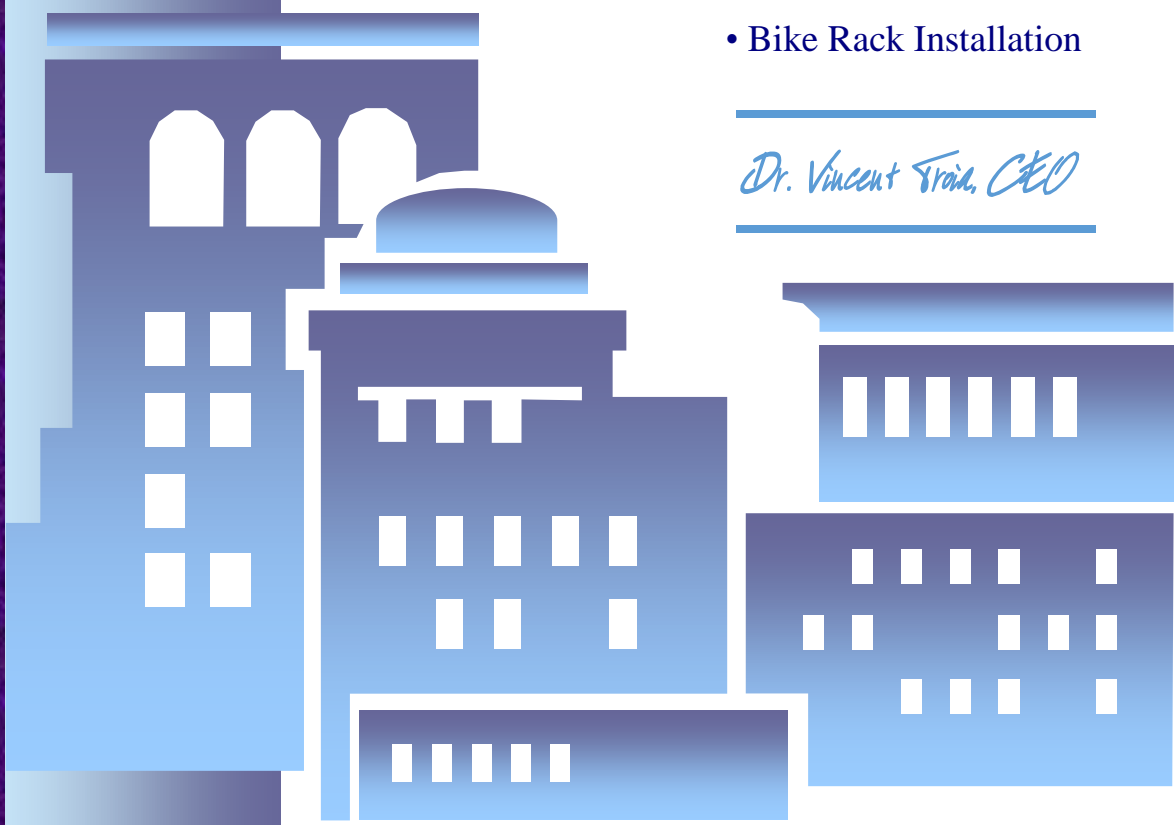

Bike Rack Planning

The Ohio River Trail Council (ORTC) works with government, businesses, community advocates, and individuals in determining the best location and design to meet their needs, and the needs of bike commuters, customers, and visitors they want to serve. More than 1.5 million bicycles are reported stolen every year in the United States, and fear of bicycle theft is recognized as a significant deterrent to bicycle use. The availability of safe and convenient parking is as critical to bicyclists in the design and operation of shops, offices, schools, and other buildings. This ORTC Bike Rack Program Guide reviews bicycle parking design, location, and installation requirements.

Bicycle parking facilities are classified into Class 1 and Class 2 facilities. Class 1 consists of lockers or racks in enclosed areas that provide security for long term. Class 2 includes stands or racks that provide protection from theft for the short term in unsupervised areas like outside a store, or for visitors to an office building, park, or Government service center.

Bicycle parking needs to be visible, accessible, easy to use, convenient, and plentiful. Racks need to support the whole bike (not just one wheel) and enable the user to lock the frame and wheels of the bike with a cable or U-shaped lock. Ideally, bike parking is located in a covered area (to protect the bike from rain, snow and other elements) by using an existing overhang or covered walkway or by constructing a canopy or roof -- either freestanding or attached to an existing building. Bike parking areas need to be well lit, and in plain view (highly visible location discourages theft and vandalism) without being in the way of pedestrians or motor vehicles. The Manual on Uniform Traffic Control Devices bicycle parking guide sign (D4-3) should be used to inform bicyclists of parking areas. It is essential, that these criteria are attained, otherwise the majority of cyclists will not use improperly installed bike racks and will park where they deem their bike will be safe and it will deter many people from using their bikes for basic transportation.



Type of Rack

The ORTC recommends that the Inverted U type bike rack (Hoop) or one of its derivatives as the best bicycle parking rack, although other racks may be proposed for specific performance requirements.

Bicycle Racks should:

- support the bicycle upright by its frame in two places
- permit the frame and one or both wheels to be locked to the rack with either a cable or U-shaped lock
- prevent the wheel of the bicycle from tipping over
- be securely affixed to concrete with tamper-proof expansion anchors
- be usable by bikes with water bottle cages
- be usable by a wide variety of sizes and types of bicycle
- resist being cut or detached using common hand tools, especially those that can be concealed in a backpack. Such tools include bolt cutters, pipe cutters, wrenches, and pry bars.



Inverted U racks are designed to hold two bikes (counts as 2 spaces), one on each side, with middle of the bike leaning against the rack (see photo). A contractor often installs bike racks incorrectly so that only one side is useful. The gangs of racks design (multiple racks on a common base) are easier to install as they have preset elements and need fewer anchors.

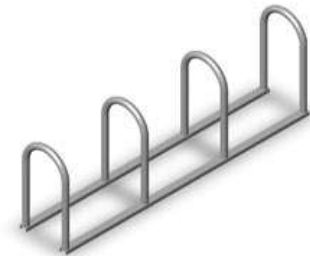



PRODUCT SPECIFICATIONS

145-1438 Standard Style Bike Rack Made of 2 7/8" Galv. Tubing, Inground Mount

SPECIFICATIONS

24 1/2" CENTER TO CENTER OVERALL WIDTH WITH A TOTAL OVERALL HEIGHT OF 38 1/2"

MADE OF 2 7/8" 12GAUGE GALVANIZED STEEL TUBING.

COATED WITH A THERMAL PLASTIC COATING TO PREVENT RUST AND SCRATCHES.

COLOR OPTIONS:

MARINER BLUE
GREEN

NO ASSEMBLY REQUIRED

ALL HARDWARE IS NON-CORROSIVE.
WEIGHT FOR THE BIKELOOPSM IS 25 LB.

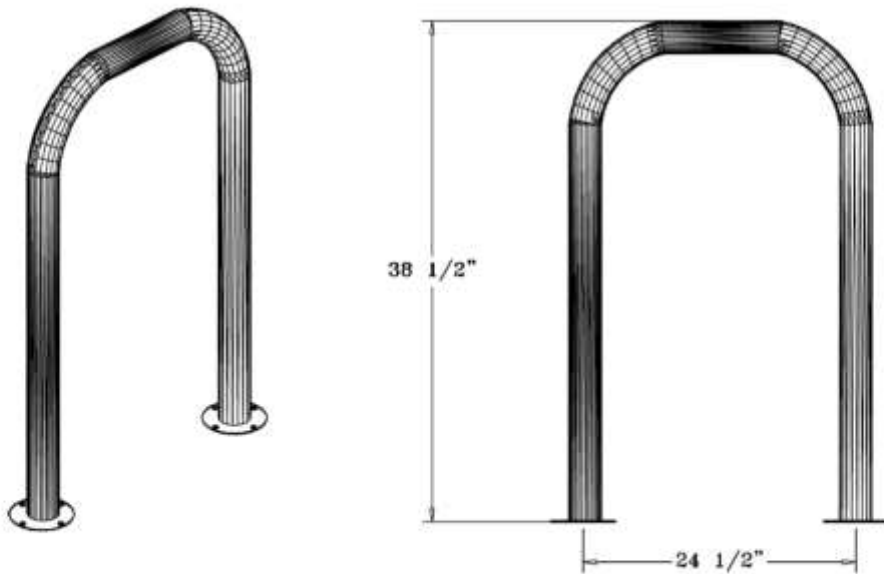

3350 NW BOCA RATON BLVD., SUITE B2 • BOCA RATON, FL • 33431
PHONE: 561.620.7878 • FAX: 561.620.8668



PRODUCT SPECIFICATIONS

145-1438 Standard Style Bike Rack Made of 2 7/8" Galv. Tubing, Inground Mount

SPECIFICATIONS

24 1/2" * CENTER TO CENTER OVERALL WIDTH WITH A TOTAL OVERALL HEIGHT OF 38 1/2"

MADE OF 2 7/8" 12GAUGE GALVINIZED STEEL TUBING.

COATED WITH A THERMAL PLASTIC COATING TO PREVENT RUST AND SCRATCHES

COLOR OPTIONS

RED

BLACK

WHITE

MARINER BLUE

GREEN

NO ASSEMBLY REQUIRED

ALL HARDWARE IS NON-CORROSIVE.
WEIGHT FOR THE BIKELOOPS IS 25 LB.

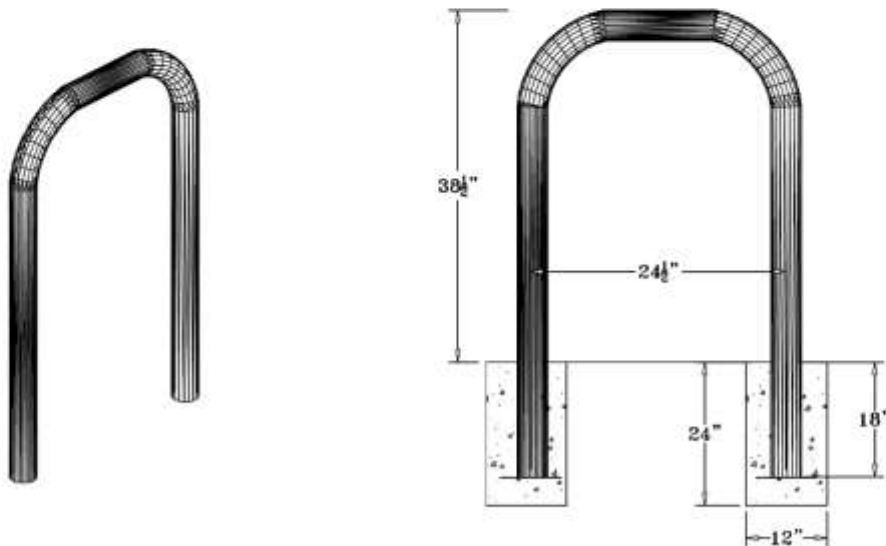

3350 NW BOCA RATON BLVD., SUITE B2 • BOCA RATON, FL • 33431
PHONE: 561.620.7878 • FAX: 561.620.8668



145 Series Color Chart



3350 NW BOCA RATON BLVD., SUITE B2 • BOCA RATON, FL • 33431
PHONE: 561.620.7878 • FAX: 561.620.8668

Short-Term Bike Parking

Short-term bicycle parking (Class II) accommodates visitors, customers, messengers and others expected to depart within two hours. It requires a high degree of convenience (as close to destinations as possible). At least some short-term bicycle parking should be protected from the weather (a portion can be unprotected, since demand tends to increase during dry weather). The location of the rack should provide easy, independent bike access. The location of a rack area in relationship to the building it serves is very important. The best location for a rack area is immediately adjacent to the entrance it serves. Racks should not be placed so that they block the entrance or inhibit pedestrian flow in or out of the building. Racks that are far from the entrance, hard to find, or perceived to be vulnerable to vandalism will not be used by most cyclists. Empty racks should not pose a tripping hazard for visually impaired pedestrians. Position racks out of the walkway's clear zone.

The rack area should be located along a major building approach line and clearly visible from the approach. The rack area should be no more than a 30-second walk (120 feet) from the entrance it serves and should preferably be within 50 feet. A rack area should be as close as or closer than the nearest car parking space. A rack area should be clearly visible from the entrance it serves. A rack area should be provided near each actively used entrance. In general, multiple buildings should not be served with a combined, distant rack area. It is preferred to place smaller rack areas in locations that are more convenient.

A bike rack is defined as one or more rack elements joined on any common base or arranged in a regular array and fastened to a common mounting surface. The rack should be installed in an area highly visible to an entrance used by building/site visitors. Inverted "U" rack elements mounted in a row should be placed on 36" centers. A minimum of 30" of clear space, free of all fixed objects such as walls and fences, must be provided in all directions of the rack. Racks should not be installed in locations that may obstruct expected pedestrian paths. This allows enough room for two bicycles to be secured to each rack element. Normally, the handlebar and seat heights will allow two bicycles to line up side-by-side if one of them is reversed. When there is a conflict, the bikes can be placed slightly offset from one another. If the racks are placed too close together, the cyclists will look for an alternative place to park or use one rack per bike and reduce the projected parking capacity by 50 percent.

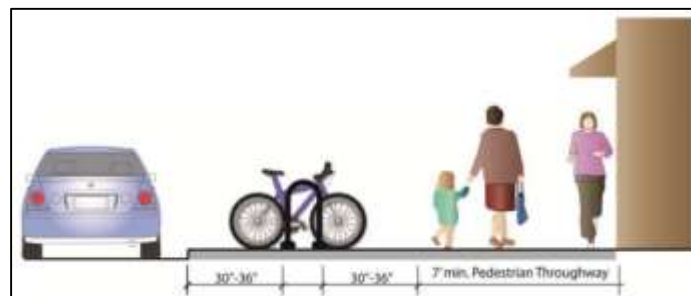

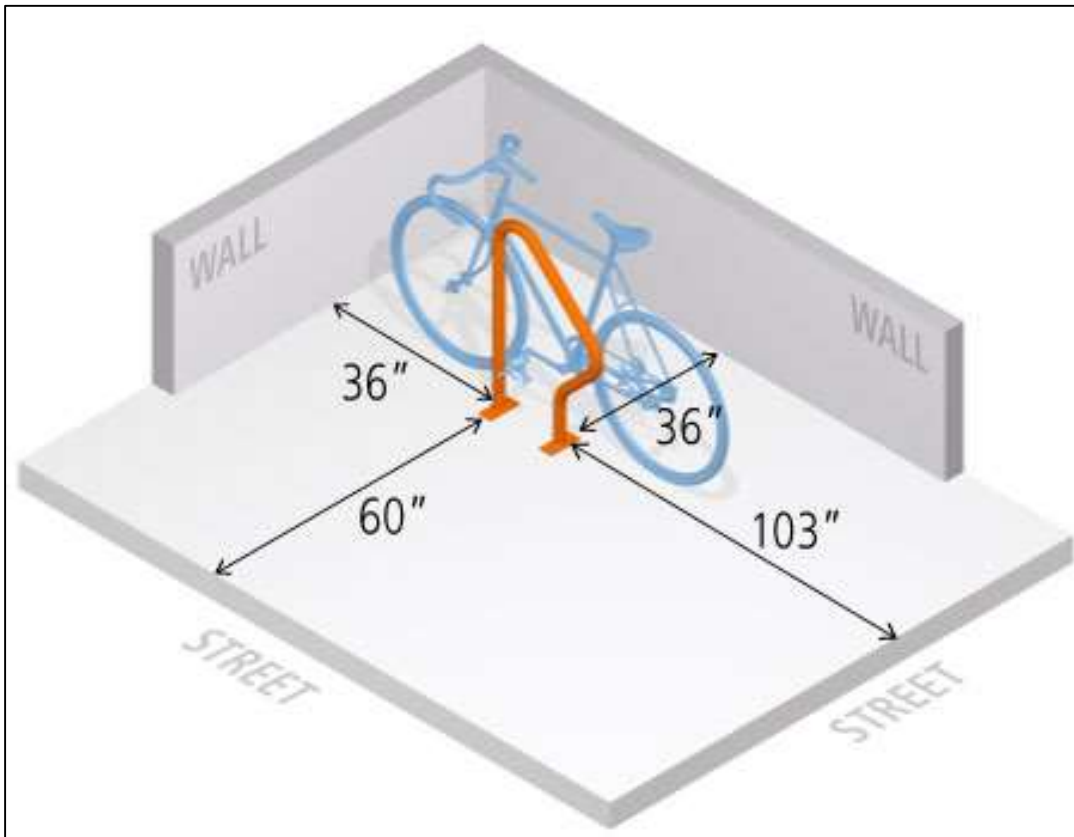
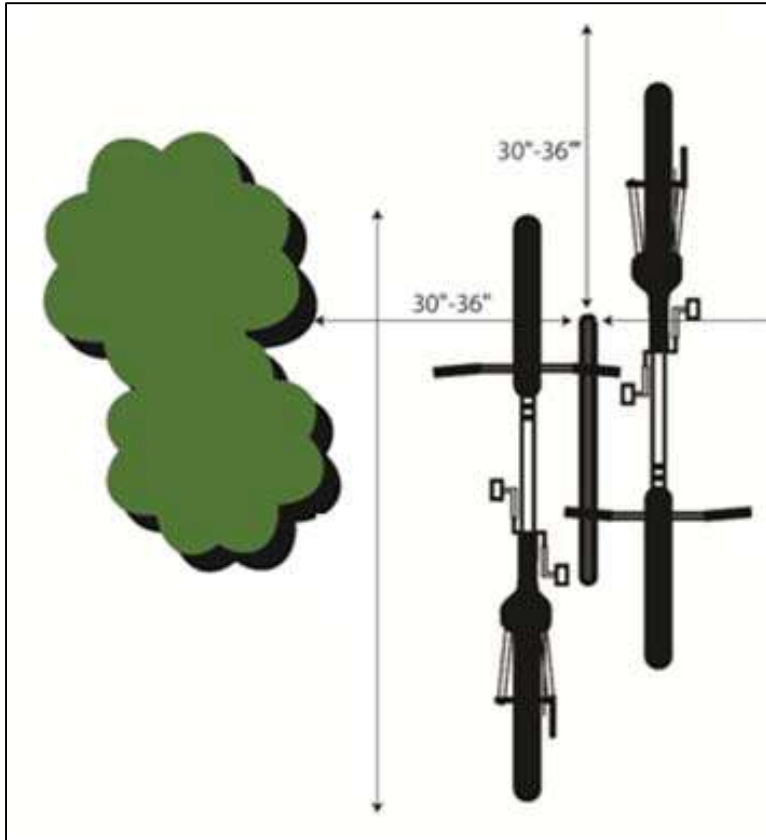

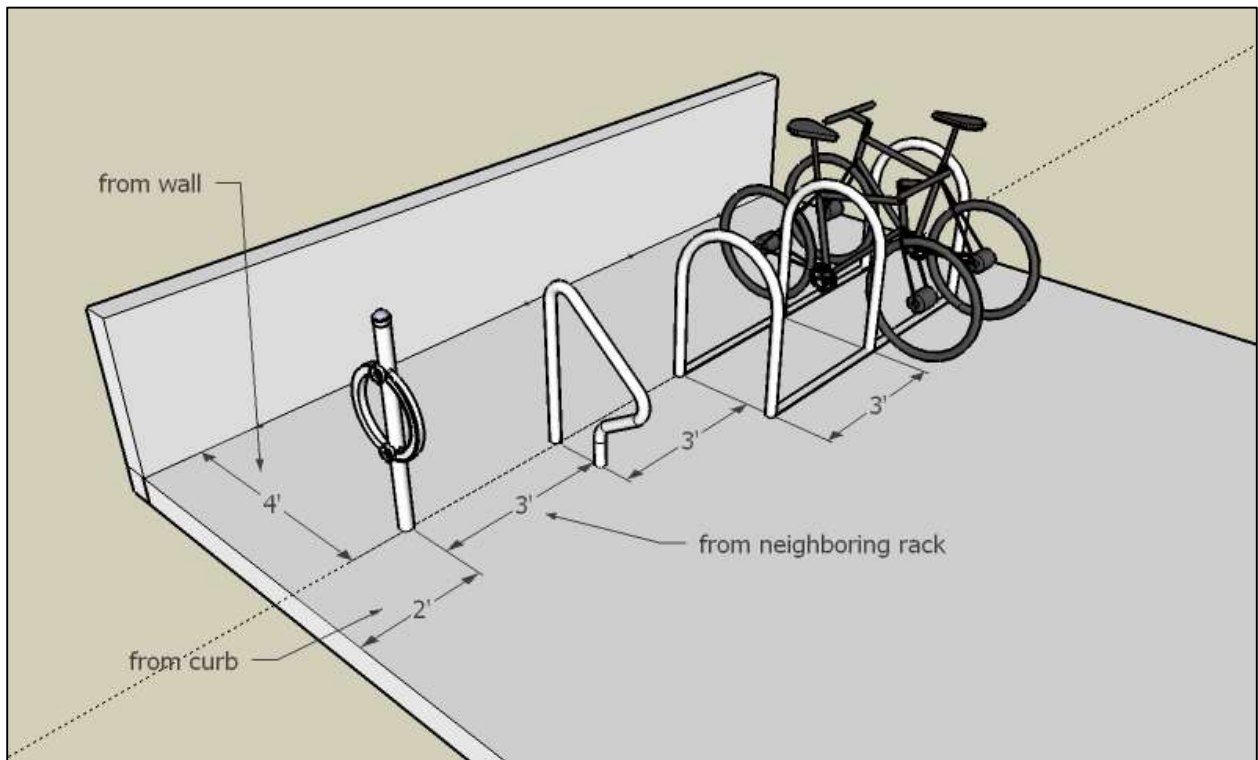
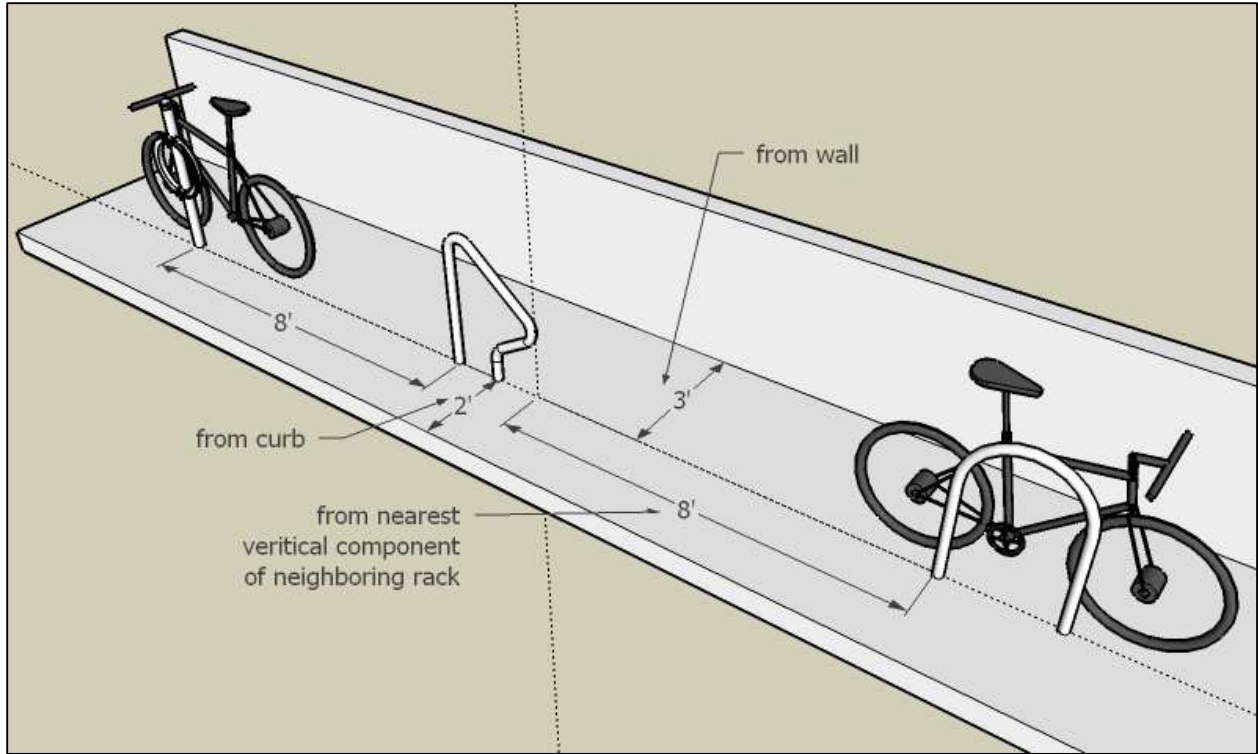

Example: U-racks placed on an angle

An example of an alternative installation for a bike rack is the U-rack placed on an angle. This type of installation has proven successful at various locations including at 1515 Arch Street.

Important considerations for this type of installation include:

- Racks placed at 45 degrees from perpendicular to the curb line require at least 42 inches between each rack on installation
- Racks must be moved further back from curb line to 34" setback
- Sidewalk walking zone space should not be reduced to less than 6 feet. This should be calculated with bicycles parked on the rack.
- Parked bicycles occupy 6 feet of linear space along the long axis of the rack. This should be used as a baseline for calculating the remaining walking space.

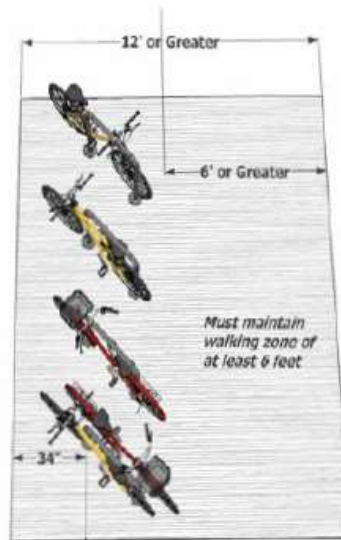
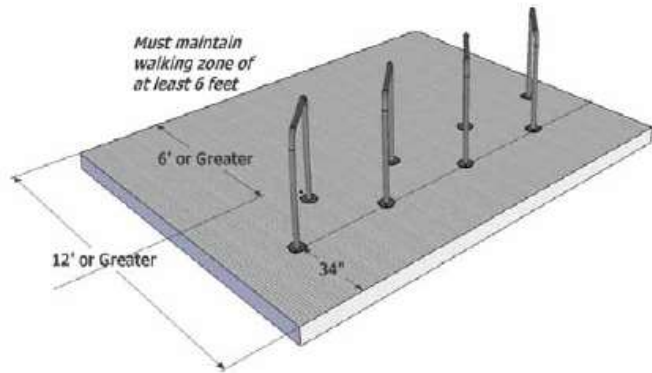

A standard bike takes up about 6 feet in length; however when offset the combined length is 8' 3".

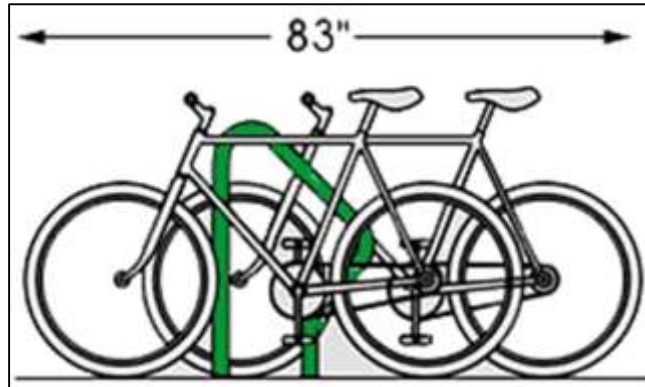

The minimum space between each rack is 3'0", more if possible, to allow for ease of access. The minimum aisle width that separate rows of racks is a distance of 4'-6", which allows one person to walk one bike. In high traffic areas, the suggested width is 6'-0". Aisle widths are measured tip to tip of bike tires between the rows of racks. Six feet should be allowed for each row of parked bicycles. Conventional upright bicycles are just under than 6'-0" long, with handlebar widths varying from 22"- 27", which is easily accommodated by these spacing recommendations.

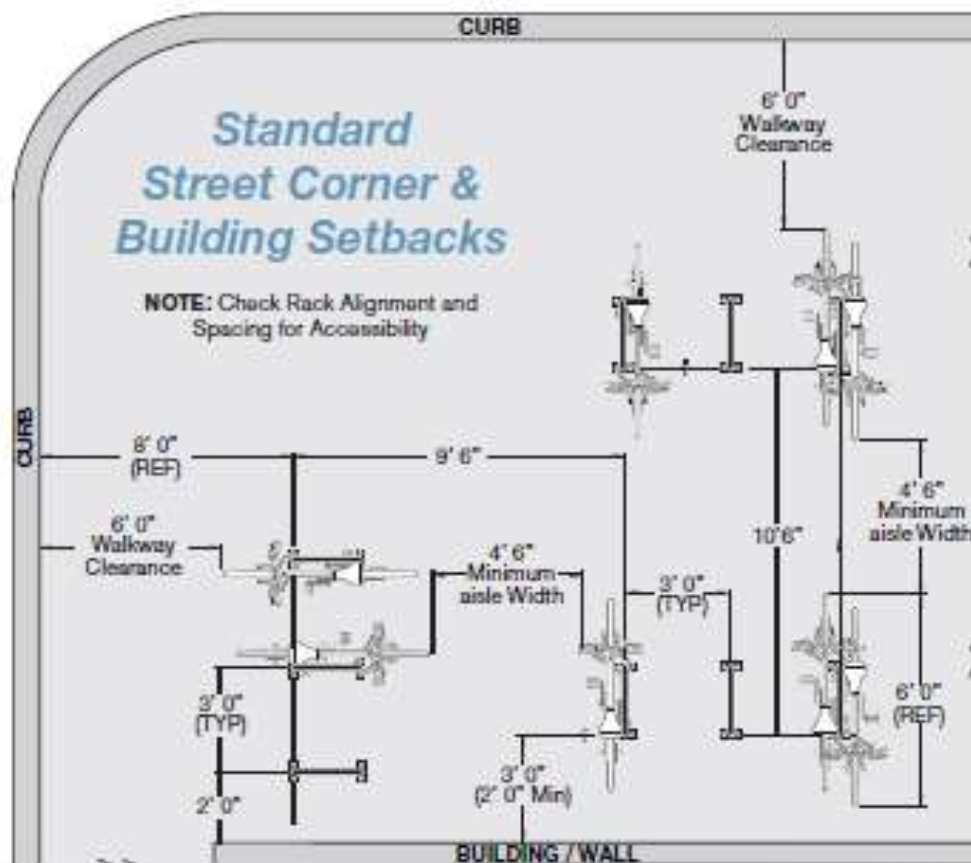

Long-Term Bike Parking

Long-term bicycle parking (Class I) provides employees, students, residents, commuters a secure and weather-protected place to store their bicycles for greater than two hours. It requires well-designed racks in covered areas, lockers, storage rooms, or fenced areas with restricted access. Locate on site or within 750 feet of the site - daily bicycle commuters are generally willing to walk a short distance, about three blocks, if they are confident the parking is secure. The following are suitable:

- A locked room or area enclosed by a fence with a locked gate.
- Within view or within 100 feet of an attendant or security guard.
- An area that is monitored by a security camera.
- A location that is visible from employee work areas.

Cyclists are more likely to park where their bicycles are safe and protected from weather. Prolonged exposure to rain can rust a bike's metal frame and components and the sun's ultraviolet rays can deteriorate a bike's soft seat and tires. Cyclists who value their bicycles will thank you for providing weather protection by giving you their business. Cover must be permanent - the cover should be designed to protect the bicycle from rainfall and be at least 7 feet above the floor or ground. At least 50% of long-term bicycle parking should be covered. Indoor storage is best.

It is often possible to find a secure room, or an area in a basement or under stairs. Bicycle parking can often use odd-shaped interior spaces that have few other purposes. Wall-mounted racks are well suited to indoor storage. Take advantage of existing overhangs or awnings - this is a creative, low-cost way of providing some weather. If there is no existing opportunity to provide cover, enclosed bicycle lockers may be the best solution. Partial cover or cover that is too high will not protect bicycles from rain and sun as well as protect cyclists from rain when they are locking or unlocking their bicycle. Locate in well-lit areas - lighting increases security of property and personal safety. In areas where security is in question or where there is limited opportunity to provide weather protection, enclosed bike lockers are a good best solution. In some situations, cyclists pay a monthly fee to lease such lockers.



LONG TERM BICYCLE PARKING

LONG TERM BICYCLE PARKING PROTECTS BOTH BICYCLES AND THEIR ATTACHED ACCESSORIES. BICYCLES CAN BE LEFT IN LONG TERM PARKING FOR DAYS AT A TIME WITH REDUCED THREAT OF THEFT AND PROTECTION FROM THE WEATHER.

• Bike Lockers

Bike lockers are fully enclosed and accessible only by the user. They are often located in parking lots, in parking garages, next to transit centers, or adjacent to buildings. Users usually lease the locker for months at a time and are either provided with a key or supply a lock of their own.



• Bike Cages

Bike cages are fully enclosed facilities that include short term racks on the inside. Access to bike cages is restricted to the owners of the bicycles stored inside. Users are either issued a key to the cage or use an employer-issued keycard for entry.



• Indoor Storage

Indoor storage rooms can be incorporated into employment or residential buildings. These rooms include short term bicycle racks at a minimum and sometimes also include other amenities such as lockers for personal items.



Please note the incorrectly installed bike racks above, which improperly supports the complete bike and reduced bike storage capacity by 50%.



Bus Stops

Avoid bike racks in bus stop zones. Develop specific bike parking lots or covered long-term storage.

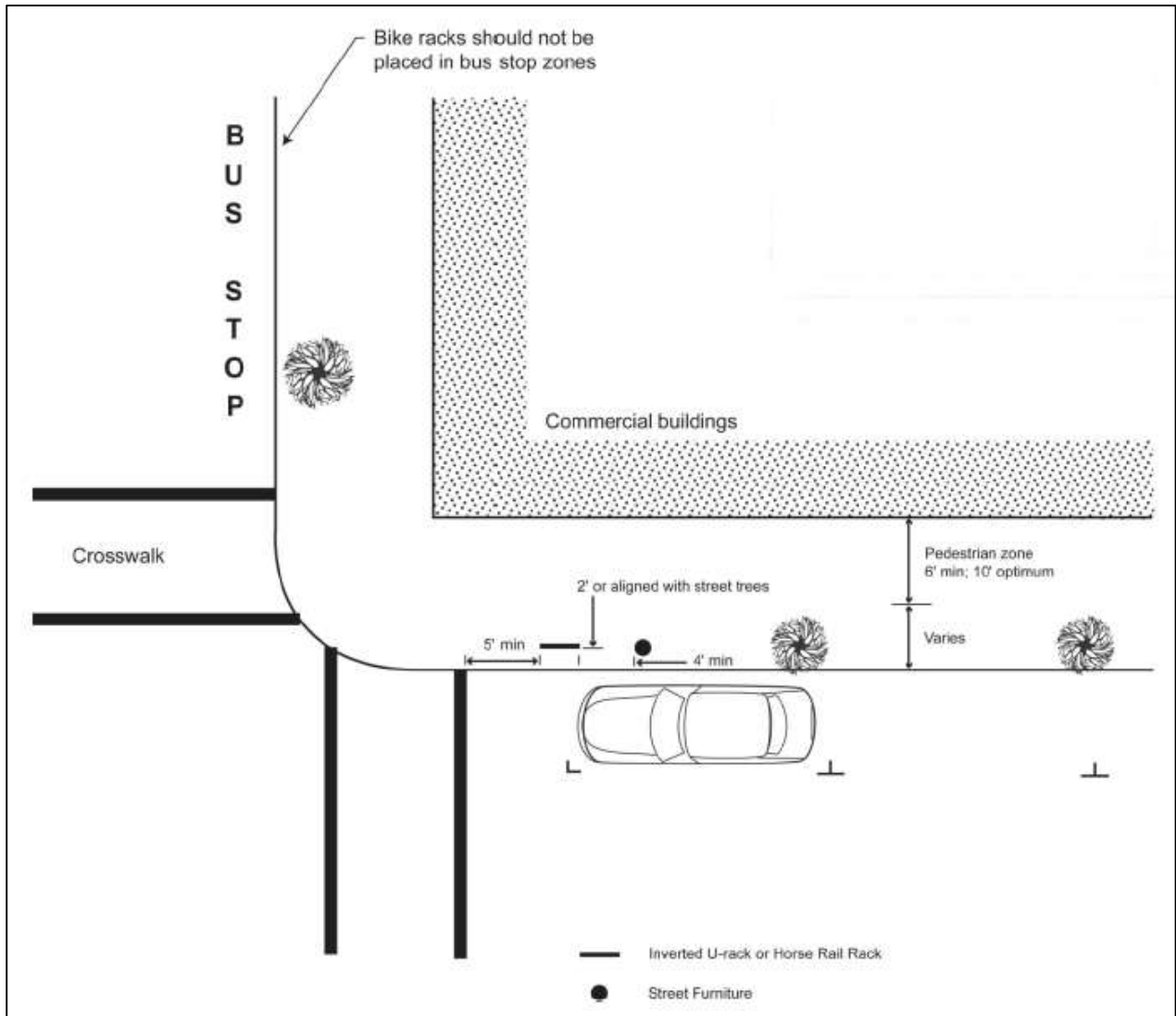

City of Philadelphia Bike Rack Spacing Guidelines

Clear Space

The minimum clear space for foot or wheelchair traffic required by the City of Philadelphia Complete Streets Handbook is 6 feet though in high-traffic areas, the minimum clearance may be 8 feet or greater.

Clearance measurements are taken with a standard bicycle parked against the rack. Practically, this means that most sidewalks 9 feet wide or less are unsuitable for bike parking in the public right of way. On busy sidewalks, this requirement for clear space may be increased depending on other factors such as commercial uses, pedestrian flows and adjacent features. Please refer to the attached diagram for illustrations of many of these obstructions. Bike racks must provide 4' clearance to utility access, trees, fire hydrants, street poles, bus stops etc. Racks should not be placed within 5' from the center line of any doorways.

Refer to information provided in the Complete Streets handbook if you have questions about the suitability of your location for a bike rack.

<http://philadelphiastreet.com/handbook.aspx>

Bike Rack Spacing Guidelines

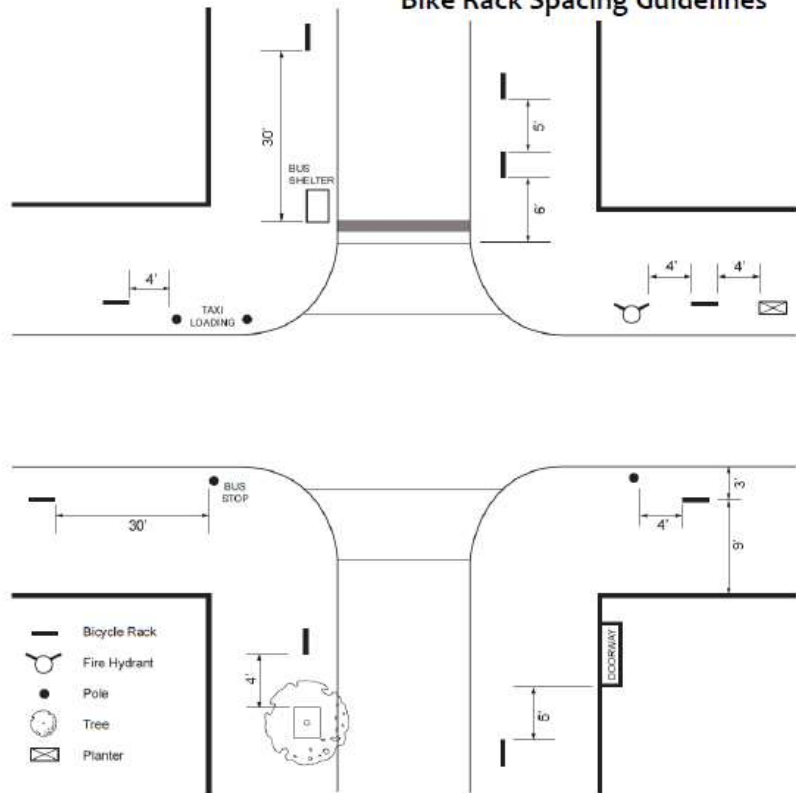

* All dimensions identified are expressed as minimums
 ** Bicycle racks are a standard 2'6" in length
 *** Clearance for bicycle racks is 45' for articulated bus routes.



Bicycle Rack Placement

BICYCLE PARKING RACK PLACEMENT

RACK PLACEMENT

RULES;

5' from:
Fire hydrant
Crosswalk

4' from:
Loading zone
Bus stop
Bus shelter
Bus bench

Min. 2', Rec. 3' from:
Curb

3' from:
Parking meter
Newspaper rack
US mailbox
Light pole
Sign pole
Driveway
Tree space
Trash can
Utility meter
Manhole
Other street furniture
Other sidewalk obstructions

WALL SETBACKS

For racks set parallel to a wall:
Min. 24", Rec. 36"
For racks set perpendicular to a wall:
Min. 28", Rec. 36"

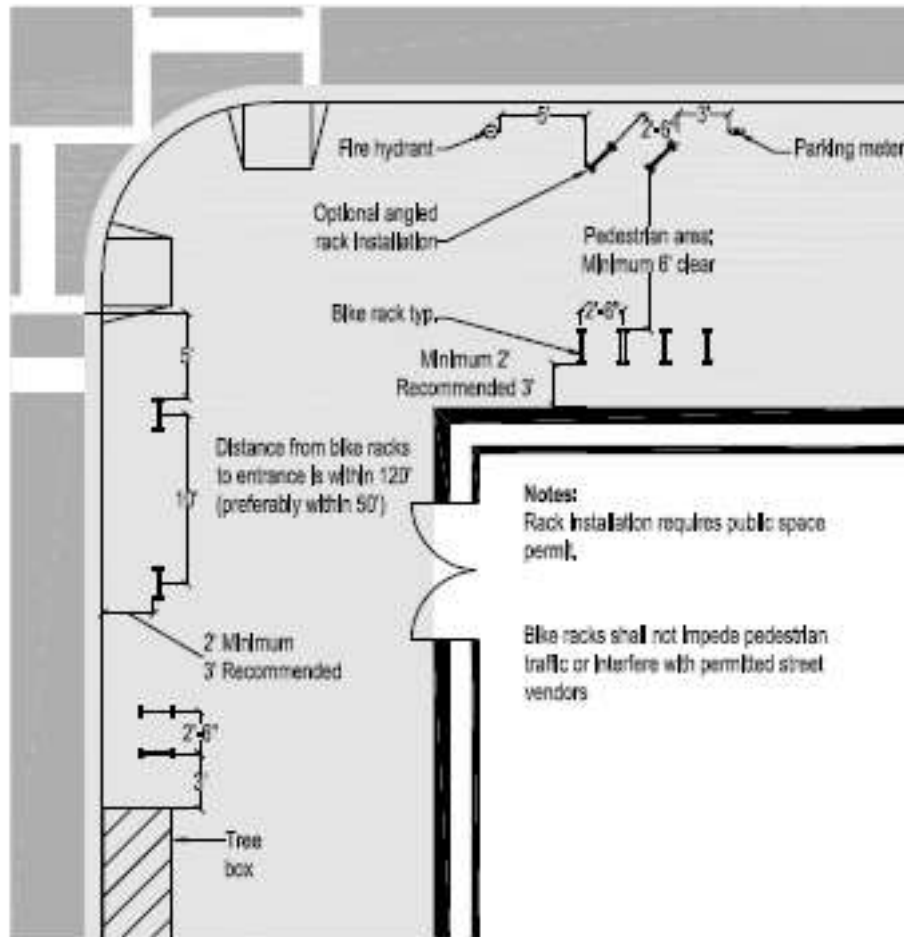

Notes:
Rack installation requires public space permit.

Bike racks shall not impede pedestrian traffic or interfere with permitted street vendors

SCALE 1" = 10'

SIDE VIEW

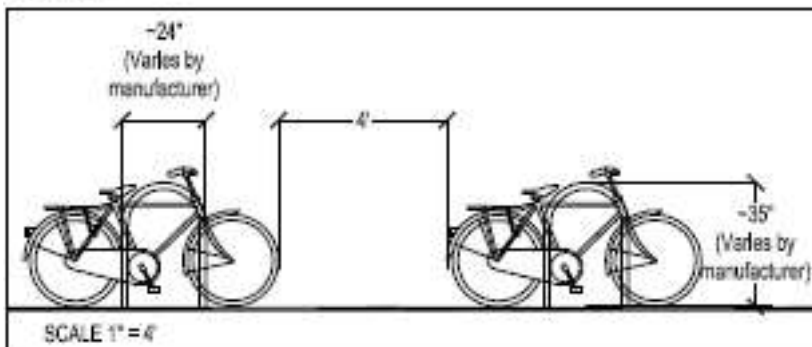

SIDE BY SIDE RACKS:

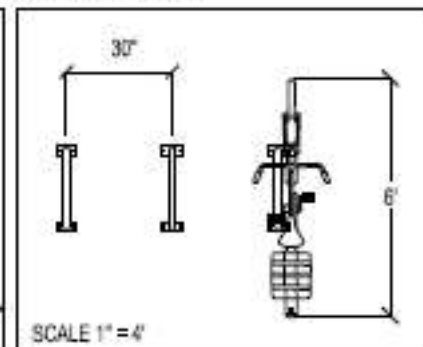

Bicycle Corrals

A Bicycle Corral is on-street bike parking which consists of bicycle racks grouped together in a common area within the public right-of-way traditionally used for automobile parking. Bicycle corrals are reserved exclusively for bicycle parking and provide a relatively inexpensive solution to providing high-volume bicycle parking. Bicycle corrals can be implemented by converting one or two on-street motor vehicle parking spaces into on-street bicycle parking. Bicycle corrals move bicycles off the sidewalks, leaving more space for pedestrians, sidewalk café tables, etc. Because bicycle parking does not significantly block sightlines, it may be possible to locate bicycle parking in 'no-parking' zones near intersections and crosswalks. Bicycle corrals may also be located on the sidewalk where roadway paving and development projects allow for large curb extensions into the parking zone, although a curb ramp, rolled curb or other device should be used to ensure bicycle access from the street is maintained.

Bicycle Corrals Benefits:

- Can be used with parallel or angled automobile parking.
- Protect bicycles from motor vehicles with physical barriers such as curbs or bollards and through application of other unique surface treatments (e.g. green thermoplastic markings) as needed.
- Establish maintenance responsibility when facility is built, particularly regarding street sweeping.
- Provide access to the bike parking from both the sidewalk and the roadway.
- Locations nearest to street corner may provide advantages to both pedestrians and motorists.

Bicycle Corrals Design Specifications:

- Solid White Thermo Plastic Reflective Tape/Paint
- 28-inch Fluorescent White Flexible Bollards with Reflective Band
- U-Shaped Bike Racks, angled 60 or 90 degrees to curb
- Bicycle Parking Sign
- Curb Painting
- 5-foot Concrete Parking Block, Painted
- On-street Bicycle Decal, Painted
- Corral dimension is 20-feet by 7-feet (or area of existing on-street parking space)
- Six U-Shaped Racks per corral to provide 12 bike parking spaces
- Minimum 30-inches clearance from the curb to centerline of rack
- Minimum 30-inches clearance between inline racks
- 48-inches clearance at access aisles, marked with painted bike decal, optional
- Galvanized finish on racks is recommended
- The Bike Corral must not extend into travel lane
- Inline locations should be chosen in front of businesses with a high degree of customer turnover.

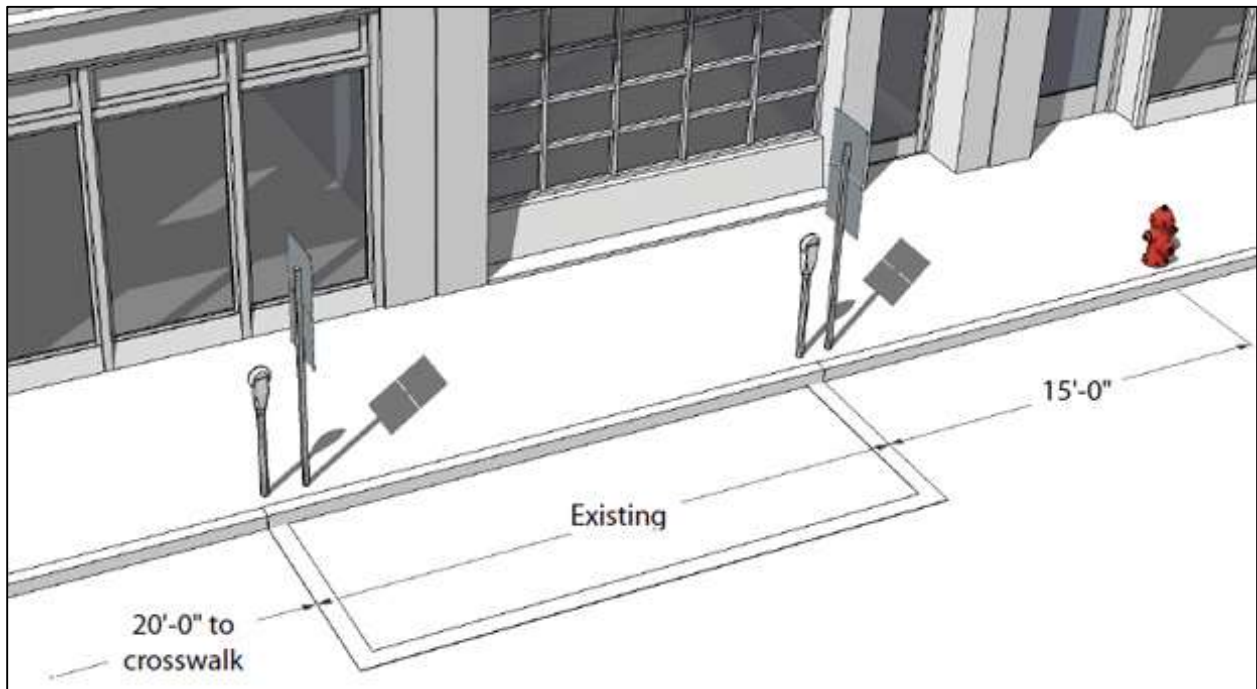
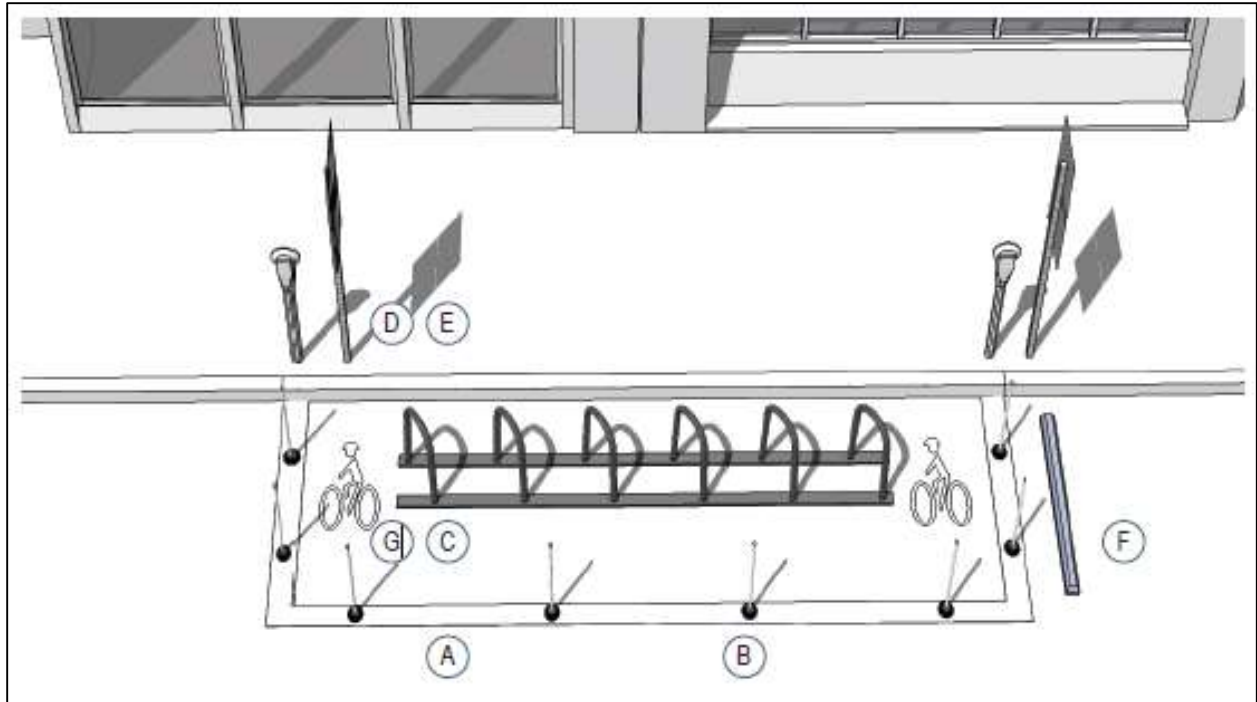

Do not install Bike Corrals within 3-feet of public or private driveway, 15-feet of a fire hydrant on the street, 5-feet of fire hydrant on a sidewalk, 20-feet of a crosswalk at an intersection, 30-feet upon approach of stop sign or other traffic control signal, 5-feet of any electrical, water or sewer utility, and at any place where official signs prohibit standing.

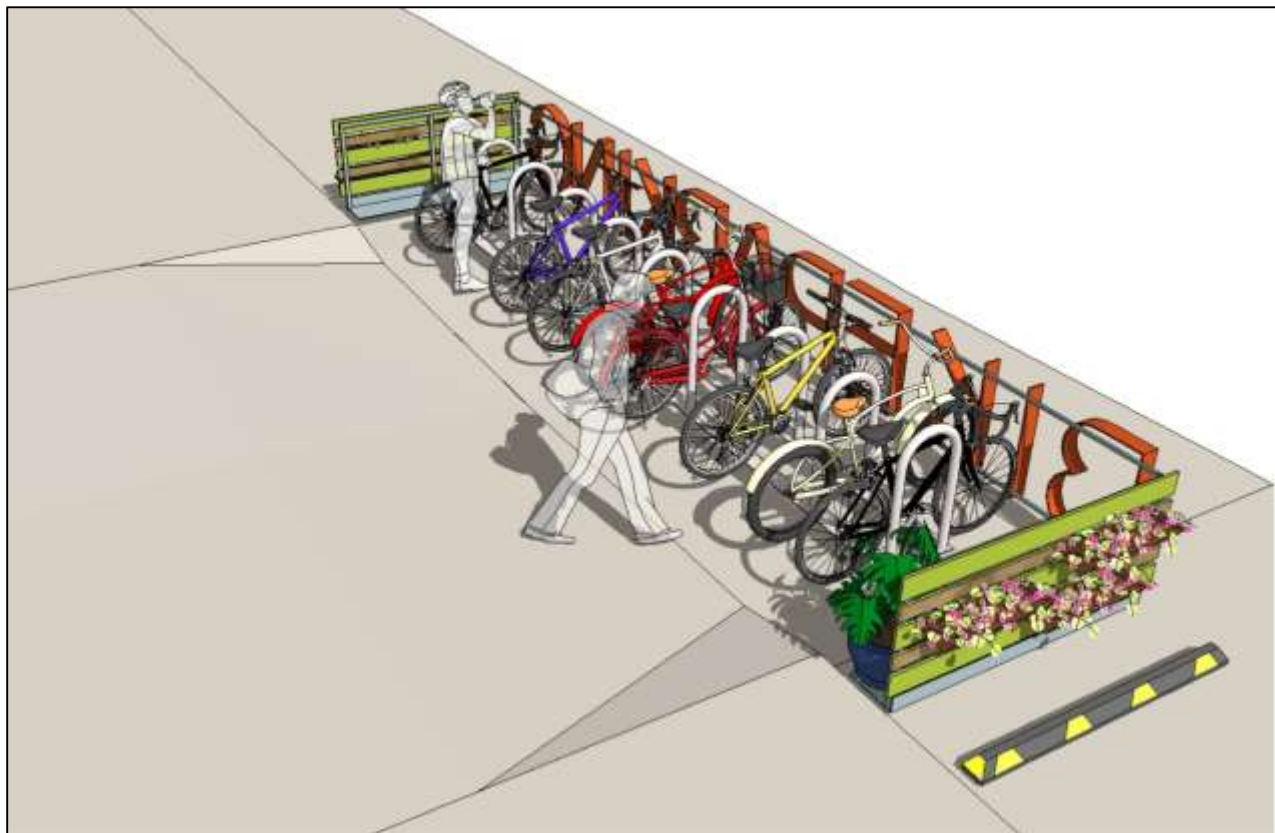
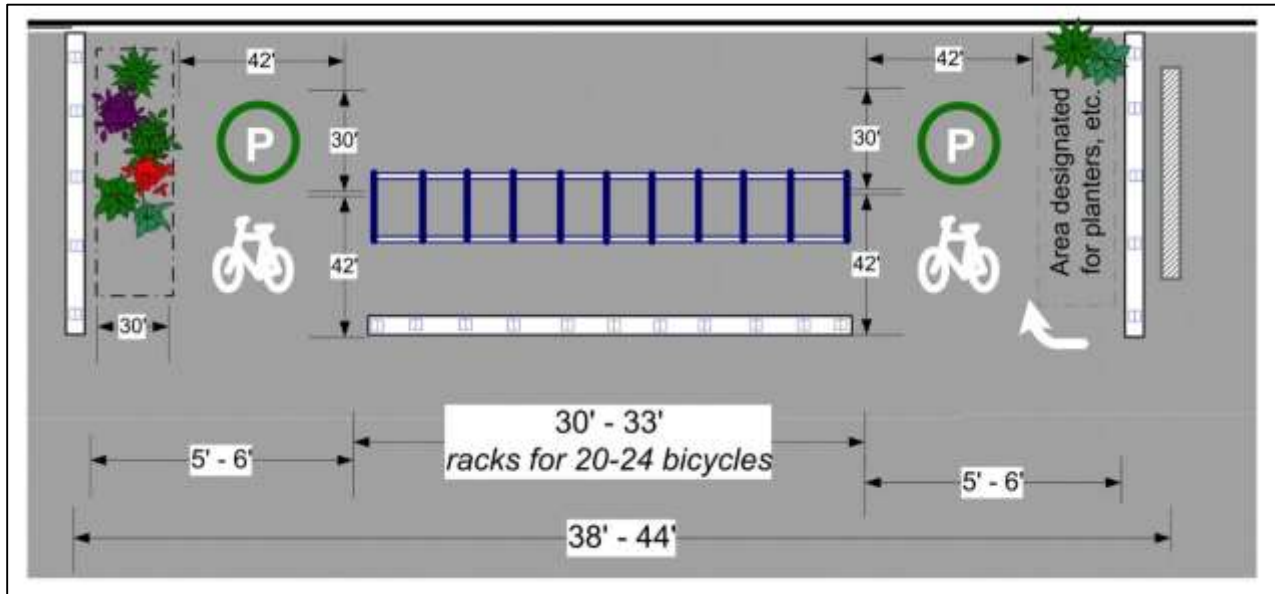

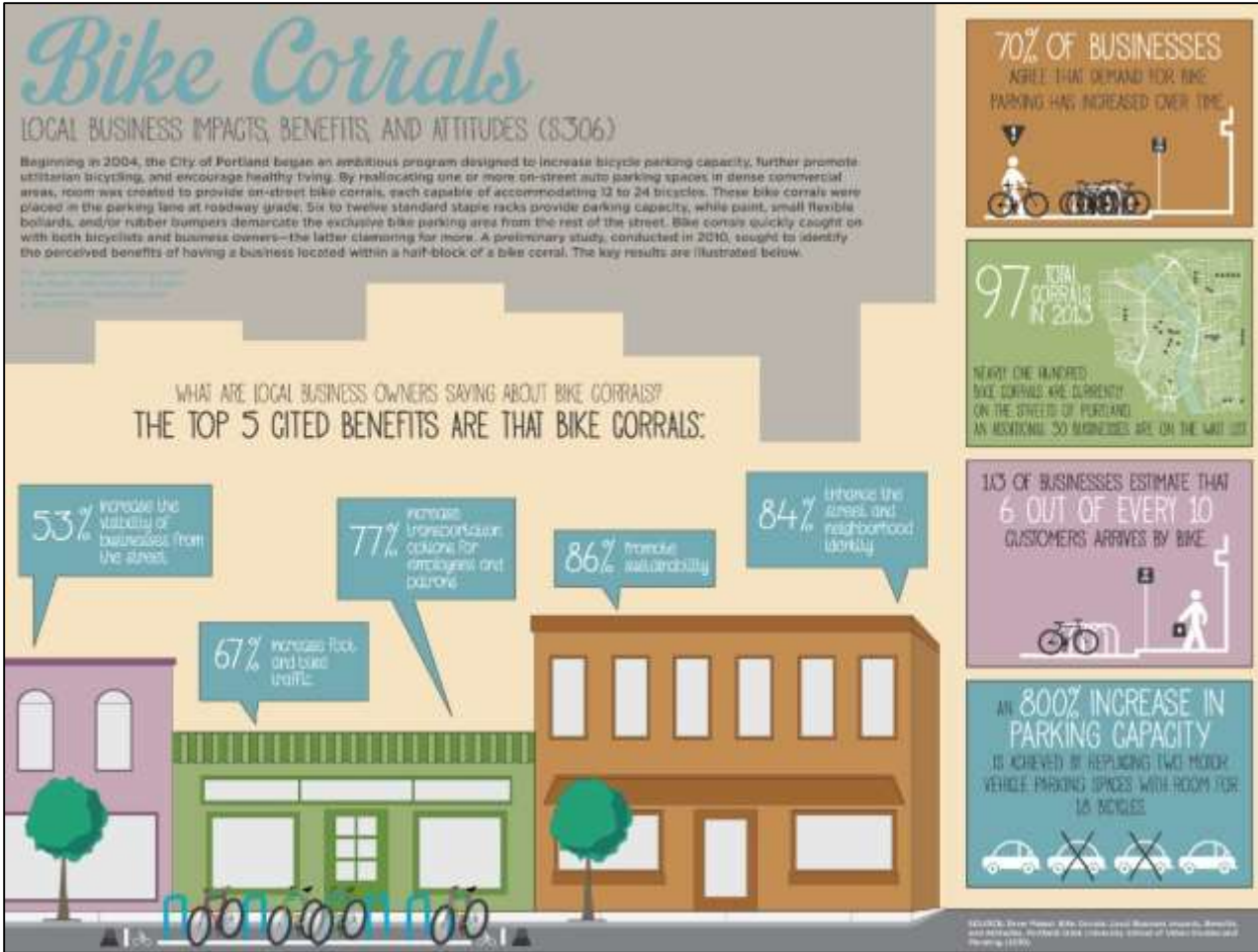



Design Summary for Bicycle Parking

Design Issue	Recommended Guidance
Rack Spacing	Position racks so there is enough room between parked bicycles. Racks should be situated on 36" recommended centers. A five-foot aisle for bicycle maneuvering should be provided and maintained beside or between each row of bicycle racks. For sidewalks with heavy pedestrian traffic, at least seven feet of unobstructed right-of-way is required.
Minimum Rack Height	To increase visibility to pedestrians, racks should have a minimum height of 33 inches or be indicated or cordoned off by visible markers.
Signing	Where bicycle parking areas are not directly visible and obvious from the right-of-way, signs at least 12 inches square should direct them to the facility. The sign should include the name, phone number, and location of the person in charge of the facility, if applicable.
Lighting	Lighting of not less than one foot-candle illumination at ground level should be provided in all bicycle parking areas.
Frequency of Racks on Streets	In popular retail areas, two or more racks should be installed on each side of each block. This does not eliminate the inclusion of requests from the public which do not fall in these areas. Areas officially designated or used as bicycle routes may warrant the consideration of more racks.
Location and Access	Access to facilities should be convenient; where access is by sidewalk or walkway, ADA-compliant curb ramps should be provided where appropriate. Parking facilities intended for employees should be located near the employee entrance, and those for customers or visitors near main public entrances. (Convenience should be balanced against the need for security if the employee entrance is not in a well traveled area). Bicycle parking should be clustered in lots not to exceed 16 spaces each. Large expanses of bicycle parking make it easier for thieves to be undetected.
Locations within Buildings	Provide bike racks within 50 feet of the entrance. Where a security guard is present, provide racks behind or within view of a security guard. The location should be outside the normal flow of pedestrian traffic.
Locations near Transit Stops	To prevent bicyclists from locking bikes to bus stop poles, which can create access problems for transit users, particularly those who are disabled, racks should be placed in close proximity to transit stops where there is a demand for short-term bike parking.
Retrofit Program	In established locations, such as schools, employment centers, and shopping areas, the City should conduct bicycle audits to assess bicycle parking availability and access, and add additional bicycle racks where necessary.



Bike Rack Installation

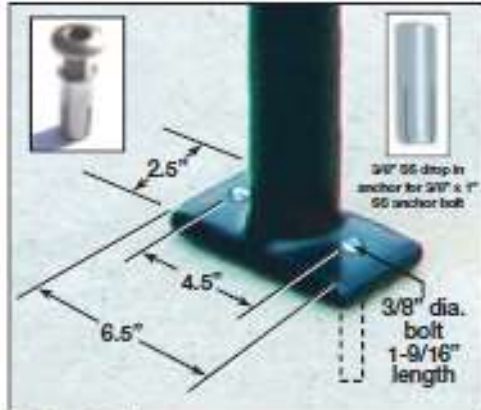

Hardware Kit-G
(Part #12716)



Set Tool (Part #12723)



◀ SURFACE INSTALLATION - U/2 Rack:

Common Tools Needed:

- Hammer Drill Motor
- Impact Wrench or Socket Wrench with 1/2" drive
- 1/2" concrete drill bit
- T-45 Torx Bit (#12721 provided)
- 3/8" Set Tool (#12723 provided)
- 2 LB. Hammer
- Concrete Adhesive
- Tape Measure
- Chalk Line
- Safety Goggles

Step 1: Determine desired placement of all bike racks before drilling any holes; avoiding concrete expansion joints. (Recommended spacing is 3-foot centers.)

Step 2: Using predetermined center lines from step 1, mark 4-hole locations for drilling using rack flange as template.

Step 3: Using the 1/2" drill bit, drill holes in the concrete - 2" deep. Do not damage the rack pipe surface or flange with the hammer drill or drill bit.

Step 4: Clean out the hole using a blow-out bulb, vacuum, or compressed air. Do not use water. It is very important to clean out the hole to ensure correct holding of the anchor.

Step 5: Insert concrete adhesive into the hole. Drop the anchor in the hole. Insert the set tool (Part #12723) into each anchor. Using a hammer, pound the set tool until the shoulder reaches the lip of the anchor. This will assure proper anchor expansion. Let the concrete adhesive cure according to mfg instructions before mounting the U-rack.

Step 6: Place rack over anchors. Place flat washer on security screw and thread into the anchor using the Torx bit (Part #12721 - provided). Wrench until flush with the flange plate.

Step 7: Check the installation to make sure it is tight to the concrete. Dispose of packaging.

Step 8: Fill in the Torx hole on the anchor with concrete adhesive.

◀ RAIL MOUNT INSTALLATION - U/2 Rack:

The CycleSafe Rail-Mount inverted-U modular design can be placed in areas where permanent anchoring is not desired. Simply use the 6 foot C-rail and place racks on top, securing with supplied tamper resistant hardware, 3/8" x 1-1/2" SS screw with washer and clamping nut.

Tools needed: T-45 Torx Bit (12721) or 7/32" hex bit, and a power drill.

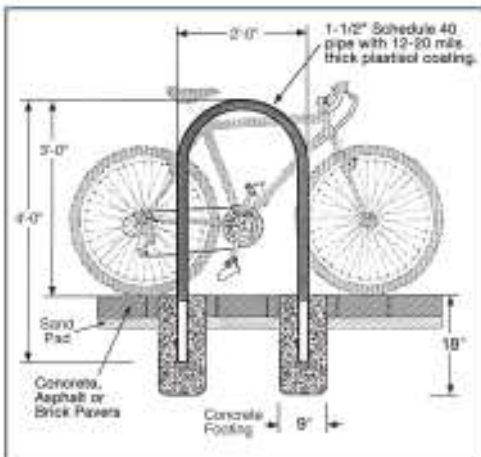

◀ IN-GROUND INSTALLATION - U/2 Rack:



Recommended installation methods for in-ground style rack:

If installing on existing concrete, CycleSafe® U/2 Bike Racks can be anchored with a non-shrink grout poured into a 4" or 6" diameter by 12" deep core drilled holes. In-ground installations for new improved surfaces 9" Sonotube forms can be put in place to create 18" footings. U/2 inverted-U racks come in optional square pipe or in two-bend configurations.

This is the standard for new construction and the most secure type of inverted-U installation. Existing concrete surface may be core drilled with a 3'-4" hole saw and filled with quikrete or a construction adhesive.

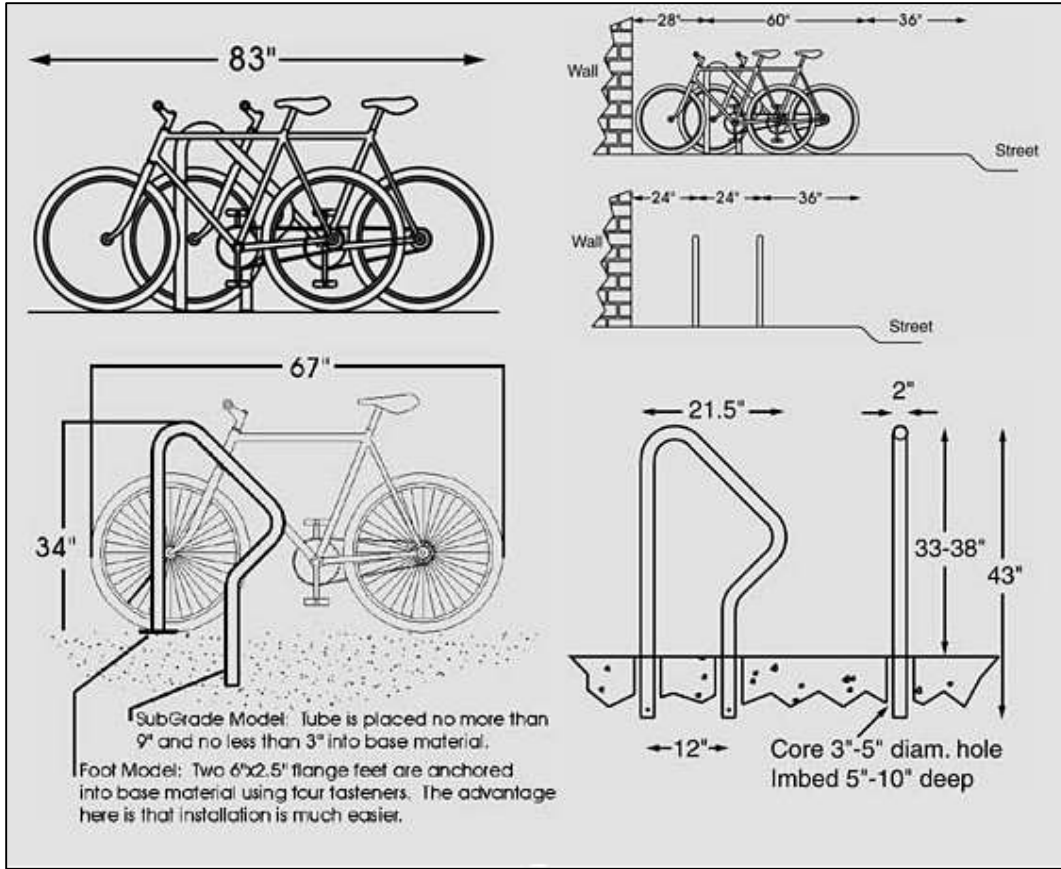
For further information contact CYCLESAFE INC.
Customer Service 888-950-6531

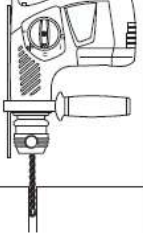
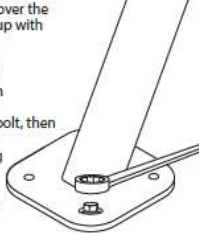
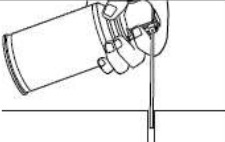
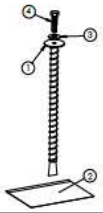
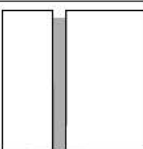
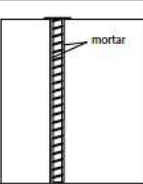

<p align="center">PARK A BIKE Asphalt Anchor Installation Instructions</p>	<p>2. Use the flange as a template to mark the placement of the holes- removing the flange once the holes are marked. Wearing eye and ear protection, insert a 7/8" bit and drill the hole to a 14" depth.</p> 	<p>6. Place the flange over the holes, lining them up with the anchors. Insert the bolt with the washer through the flange and finger-tighten the bolt, then use a box wrench to finish tightening 3-4 full turns. Wait 1 hour before using the rack.</p> 
<p>TOOLS NEEDED FOR INSTALLATION</p> <ol style="list-style-type: none"> 1. Safety glasses and ear plugs 2. Hammer drill w/ 7/8" x 16" carbide masonry bit 3. Soft face mallet 4. 9/16" box wrench 5. Compressed air 6. 4 oz. water <p>NOTE: These instructions are for installation of strike anchors in ASPHALT ONLY.</p> <p>CAUTION: Be sure to wear eye and ear protection when drilling holes.</p>	<p>3. Clean out and around the holes with a small blast of air.</p> 	<p>For questions or concerns regarding installation using asphalt anchors, please call Park A Bike at 800-630-7225 or email us at Info@parkabike.com.</p> <p>These installation instructions are intended for the install of asphalt anchors in asphalt only. For instructions on installing a bike rack in other surface materials, please contact Park A Bike or download our installation instructions for our concrete anchors.</p>
<p>In the Kit:</p> <ol style="list-style-type: none"> 1. Asphalt anchor assembly, 3/8 X 16UNC 2. Quick set anchor mix 3. Galvanized steel washer 4. Hex head bolt 3/8" X 16UNC -1-1/2" <p>Quantity depends on which kit was purchased.</p> 	<p>4. Add 4 oz. of water to every 16 oz. of anchor mix, stirring the mix as water is added. The mortar should be a thick paste. Pour the mortar to fill the hole.</p> 	<p>5. Drop in the anchor, making sure it's aligned and flush with the top of the hole. Use a soft face mallet to drive the anchor into the hole if necessary. Remove any excess mortar and wait 15 mins before proceeding to the next step.</p> 
<p>1. Place the rack on the surface where it is to be mounted, checking for set backs to walls, curbs, pedestrian walkways and wheelchair accessible areas.</p> 	<p align="right">  smart racks smart solutions www.parkabike.com info@parkabike.com 800-630-7225 </p>	

Bicycle Parking Sign



Bike Parking Maps

Publicize the availability and location of bicycle parking in marketing, advertising and informational maps and pamphlets, especially long term covered parking.

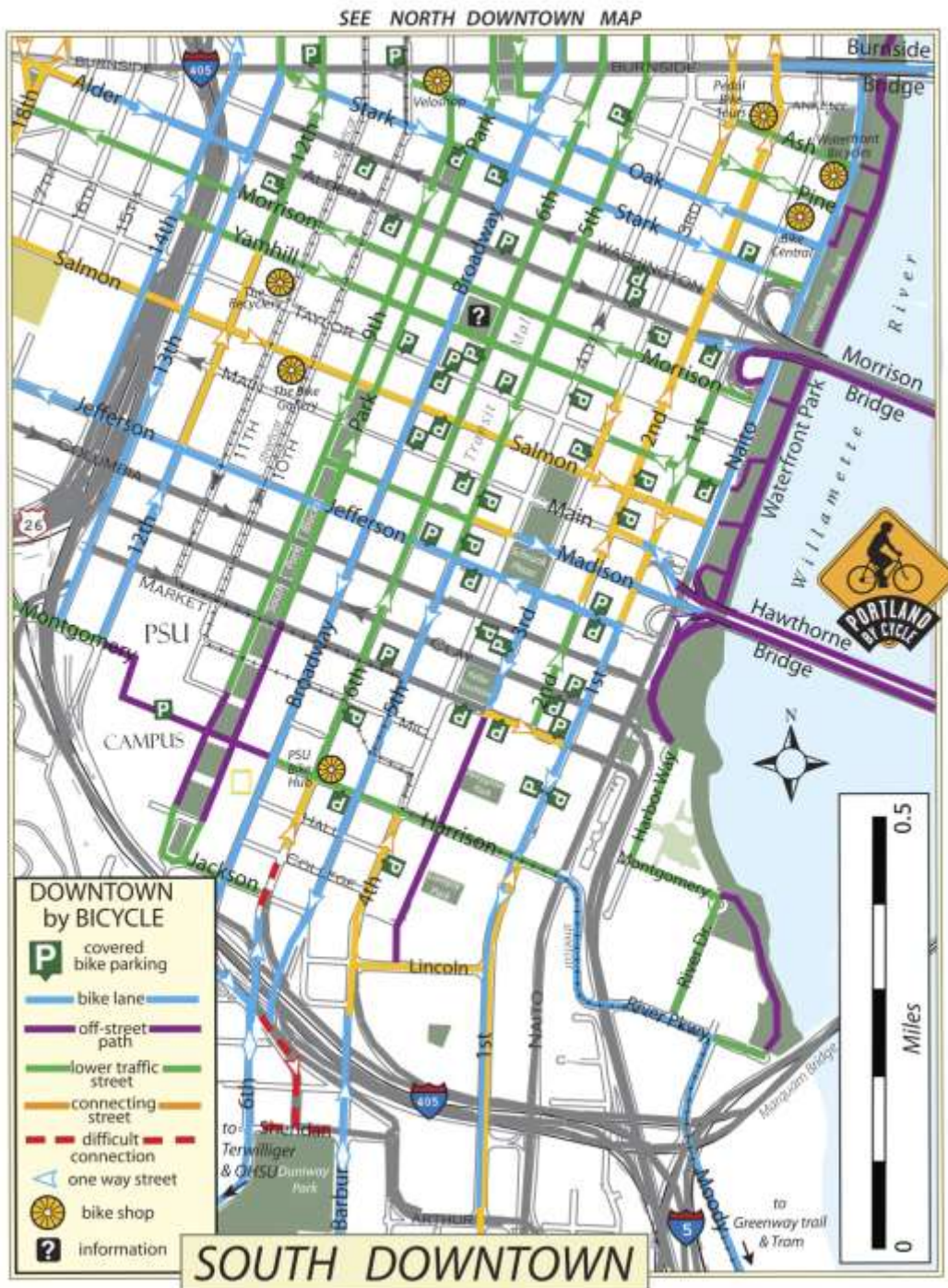

Bike Locking Tips

- Always lock your bike's frame and a wheel with a high quality, modern U-lock with a flat or disc key. Cylindrical keyed locks are more easily picked.
- Add a cable, cable lock, or second U-lock to lock the second wheel.
- Remove all detachable items like lights, bags and quick release parts and take them with you.
- Consider a bike seat lock. You do not want to try riding home without a seat.
- Use a bike rack that is firmly affixed to concrete.
- Front wheels are less expensive than back wheels which have special gears and cost about twice as much, so if you can only protect one wheel, safeguard the back one.



Methods:

1. Lock the rear wheel and the frame with a U-lock and use a cable to secure the front wheel.
2. Lock the front wheel and frame with a U-lock. Not recommended since it is best to protect the more complex rear wheel.
3. Lock the back wheel and the rear triangle with a U-lock. A quick release front wheel could also be locked with the rear triangle or take the front wheel with you.

BEST LOCK POSITION



METHODS

1. Lock the bike frame and wheels together
2. Securing the quick release front wheel alongside the frame and rear wheel

Locking only the front wheel to a bike rack element is a good way to lose a rear wheel or the rest of the bike.





Bike Rack, Bicycle Locker, Cycle Stand, Bike Storage, and Bicycle Station Manufacturers Directory

[American Bicycle Security Company](#) PO Box 7359 Ventura, CA 93006 USA. Tel: 1-800-245-3723 (US & CAN).

E-mail: turtle@ameribike.com. Lockers and racks.

[Bikebox Canada](#) P.O. Box 22116, Saskatoon, Sask. S7H 5P1 CANADA. The unit is triangular shape. Five units fit into a ninety-degree corner, fifteen units on an outside corner, ten units in a semicircle along a wall, or twenty units form a circle. The units are also stackable.

[Bike Guard](#), PO Box 520, Rexburg, ID 83440. Tel: 1-208-356-0744. Fax: 1-208-356-7333

Email: bikegd@ida.net. Modular one-bike lockers.

Bike Lokr, PO Box 720005, Norman, OK 73070. Tel: 1-800-245-3565

[Bike Parking](#), Palmer Group, PMB 328, 1072 Folsom Street, San Francisco, CA 94103. Tel: 1-888-764-BIKE (2453) or 1-415-333-6428. Fax: 1-415-333-2032. Email: info@bikeparking.com. Lockers and racks. Bicycle racks designed to shield the user's U-lock or padlock from attack by thieves.

[Bike Stand with Pump](#) Winner of Dutch Design Award 2006

[Bike Tree](#), World Trade Center II, 29, Route de Pré-bois, CP 134, 1215 Geneve 15 Suisse (Switzerland). Tél : ++41 22 788 88 88. Fax: ++41 22 788 76 76. Email: cfy@bike-tree.ch. Hanging, sheltered bike storage.

[Bike Tree \(North America\)](#) 5972 181A St, Surrey BC V3S 5P3 Canada. Tel: 604-581-5722. Fax: 604-581-4822. Email: biketree@telus.net.

[Bike-Up®](#) and [CycleRax](#) Bicycle Parking Systems, 6 Antares Drive, Phase II, Unit #10B, Nepean, Ontario K2E 8A9 Canada. Tel: 1-613-226-6452. Fax: 1-613-228-3539. Email: len@bikeup.com. Bike racks: both horizontal and vertical to fulfill every parking need.

[Bikekeeper](#), Aerbike Holland BV, Bedrijvenpark Twente 99, NL-7602 KD Almelo, The Netherlands. Tel: +31 (0)546 566487. Fax: +31 (0)546 566934. Email: info@bikekeeper.nl. Racks and ports.

[BikeLid](#), 825 Third Ave., 30th Floor, New York, NY 10022. Tel: 212-893-8262. Fax: 212-838-4533. info@bikelid.com. BikeLid's advanced design security cover offers: no assembly, install on any surface, two-year warranty, 90% recycled materials used, user-supplied or assigned-key locking systems, ground clearance for enhanced security

[BikeLink](#), 800 Heinz Avenue, Suite 11, Berkeley, California 94710. Tel: 510-549-9258. Fax: 510-549-9157. Email: info @bikelink.org. On-demand or reservable, electronic bicycle lockers.

[Chingor Mechanical Co., Ltd.](#), Wang Ga Industry, Ningbo, Zhejiang, China 315016. Tel: (86 574) 8611 9083. Fax: (86 574) 8611 9082. Email: carol @chingor.com. Manufactures rack for bike parking, provide OEM service. Alternate website [chingor.en.alibaba.com](#).

[Columbia Cascade](#), 1300 S.W. Sixth Avenue, Suite 310, Portland OR 97201-3464. Tel: 503/223-1157. Racks and locker manufacture.

[Cora](#). Tel: 1-800-354-8624. Email: info @cora.com. Racks and locker manufacture.

[Creative Pipe, Inc.](#) P.O. Box 2458, Rancho Mirage, CA 92270-1087. Tel: 1-800-644-8467. Tel: 310-376-9536, Fax: 310-798-1785. Email: pap @creativepipe.com. Produce racks and lockers.

[Cyclepods](#), 5 Churchill Court, Hortons Way, Westerham, Kent TN16 1BT UK. Tel: 0845 094 0490. Fax: 0845 094 0151. Email: info @cyclepods.co.uk. Stylish, space-saving, flexible and secure. Mention promotional code IBF10 for a discount.

[Cycle-safe](#), Bicycle Parking Systems, 5211 Cascade Rd SE, Suite 210, Grand Rapids, MI 49546. Tel: 616-954-9977. Fax: 616-954-0290. Email: info @cyclesafe.com. Vendor of bicycle lockers, bicycle racks and covered cycle parking systems.

[Cycle Stops](#), 1000 Bluff Industrial Boulevard, Columbia, SC 29201, 803.479.9235. Email: stewartsneed @cyclestops.com. Design and manufacture bicycle parking racks.

[Dero](#), 1429 Washington Ave. South - Suite 2, Minneapolis, MN 55454-1000. Toll free: 888-DERO-RAX (888-337-6729). Tel: 1-612-359-0689. Fax: 1-612-341-3356. E-mail: dero @dero.com. Products for schools, offices and home.

[Dobra Design](#), 4230 Blenheim St., Vancouver, B.C., Canada V6L 2Z4. Tel: 1-604-733-9486. Fax: 1-604-739-1833. Email: info @dobradesign.com.

[Dura Locker](#), 4019 Leos Ln #3, Carmichael CA 95608. Tel: 1-800-722-2453. Email: info @duralocker.com

[Falco](#), Weitzelweg 8, NL 7671EJ Vriezenveen, The Netherlands. Tel: +31-546-554444. Fax: +31 546 561115. Lockers and racks.

[Function First Bike Security](#), P.O. Box 882, Covallis, OR 97339. Tel: 1-451-738-0773 or 1-888-BIKERIB (1-888-245-3742). Fax: 1-503-296-2335. Email: bikeribs @comcast.net. Manufacturers of bicycle security and storage products. Includes dimensioned specification sheets.

Guardian Bicycle Locker System SPI Industries Inc. Shallow Lake, Ontario, N0H 2K0 Canada. Tel: 800-269-6533 or 519-935-2211. Email: spi @spiplastics.com. Low maintenance Bike Locker manufactured from plastic. Bicycle is fully contained with hook for helmet and riding gear.

Highland Products Group. Proliferating websites: [Bicycle Rack Source](#), [Bike Rack Source](#), [Commercial Bicycle Racks](#), [Indoor Bike Racks](#), [Metal Bike Racks](#), [Outdoor Bike Racks](#), [Parking Lot Stop](#), [Parking Stop Source](#), [Parking Lot Supply](#). Email: sales@bicycleparkingracks.com

[Huntco Supply LLC](#), Portland, OR. Tel: 800-547-5909. Email: sales @huntco.com . Manufacturers of bicycle racks and lockers, trash receptacles, ash urns and planters.

[Josta Bike Parking System](#) Munster, Germany. Bicycle racks and sheds.

[Keystone Ridge Design](#), P.O. Box 2008, Butler, PA 16003. Tel: 800-284-8208. Bike racks.

[Locktec](#) (Velosafe), Unit 7-11, Pentlandfield Business Park, The Bush, Roslin, Midlothian, EH25 9RE, Scotland, UK. Tel: 44-131-445-7788. Fax: 44-131-445-7527. Email: locktec @locktec.ndirect.co.uk

[Madrax](#) (a division of Trilary Inc.), 1080 Uniek Drive, Waunakee, WI 53597 USA. Tel.: 1-800-448-7931. Tel.: 1-608-831-9040. Fax: 1-608-831-7623. Email: sales @madrax.com. Produces bike lockers and bike racks.

[Park A Bike](#) - Manufacturer of bike parking systems and security lockers. Rack systems from 2 to 18 bikes.

[The Park Catalog: Bicycle Racks](#), Highland Products Group, 3350 NW Boca Raton Blvd., Suite B2, Boca Raton, FL 33431. Tel: 888-447-2401. Tel: 561-620-7878. Email: sales @theparkcatalog.com. Bicycle racks, picnic tables, park benches, grills, bleachers trash receptacles and a wide array of products for parks departments, municipalities, and outdoor recreation facilities.

[Peak Racks](#) "Rack with Plaques," a program where municipalities get bike parking at no cost. Tel: 805-541-8022

[Pendula](#), Myrholn 33, 78542 Mockfjärd, SWEDEN. Tel: +46 241-20929. Email: info @pedula.se. Reduce footprint bicycle garage / locker.

[Ribbon Rack](#), A A A Ribbon Rack Co., Division of Bandir International, 521 Fifth Avenue, 17th Floor, New York, NY 10175-0038 USA. Tel: 1-212-505-6500 Fax: 1-212-505-6813. Email: info @ribbonrack.com

[Saris](#). Grid style, inverted U's, Waves, vertical wall mount and high security parking and storage solutions.

SchoolLockers. 2895 South 300 West Salt Lake City, UT 84115. Tel: 801-493-0121
Email: lockers @schoollockers.com. Lines of bicycle lockers including steel bike lockers, polyethylene solid plastic bike lockers, and perforated steel bike lockers.

SecuraBike, Australia. Bicycle racks, lockers, cages, shelters, etc.

Sunshine U-Lok Corporation, 31316 Via Colinas, Suite 102, Westlake Village, CA 91362. Tel: 818.707.0110. Toll free: 800.548.1344.

Urban Racks. Manufacturing and sales of bicycle rack systems. Tel: +1-888-717-8881
Velo-parc, PO Box 3283, Glasgow, Scotland G41 3ZG UK. Tel: 0141 636 1720. Fax: 0141 636 9054. Email: info @velo-parc.com.

Bike Rack for Buses

Sportworks, 15540 Wood-Red Rd NE, A-200, Woodinville, WA 98072. Tel: 425-483-7000. Email: customerservice @sportworks.com.

Reference: <http://www.ibike.org/engineering/parking-equipment.htm#Conventional>

Dero Commercial Bike Racks





DERO

SWERVE RACK

- High security
- Inexpensive bike parking
- Several mounting options available

The design of the Dero Swerve mirrors the bike frame, thus providing superior bike support while making it easy to secure both the bike frame and wheel with a standard u-lock. Dero Swerve Racks are popular with architects and universities because of their aesthetic design and space efficiency.



DERO
A PLAYCORE Company

 www.dero.com  1.800.337.6729



Printed on recycled paper

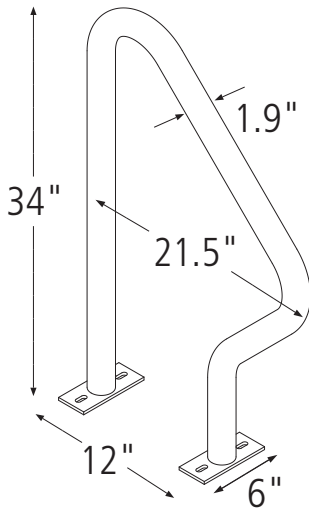

Product Dero Swerve Rack
As manufactured by Dero Bike Racks

Capacity 2 Bikes

Materials 1.9" OD schedule 40 pipe

Finishes An after fabrication hot dipped galvanized finish is our standard option. 250 TGIC powder coat colors, thermoplastic coating, PVC dip, and stainless steel finishes are also available as alternate options.

Our powder coat finish assures a high level of adhesion and durability by following these steps:

1. Sandblast
2. Epoxy primer electrostatically applied
3. Final thick TGIC polyester powder coat

Stainless Steel: 304 grade stainless steel material finished in either a high polished shine or a satin finish.

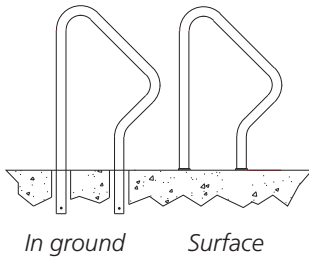

In ground *Surface*

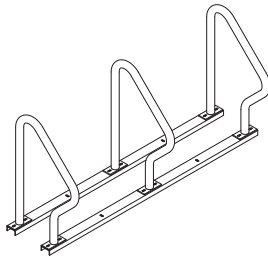

Rail (freestanding)

Installation Methods

In ground mount is embedded into concrete base. Specify In Ground Mount for this option.

Foot Mount has two 2.5"x6"x.25" feet with two anchors per foot. Specify Foot Mount for this option.

Rail Mounted Swerves are bolted to two parallel rails which can be left freestanding or anchored to the ground. Rails are heavy duty 3"x1.4"x3/16" thick galvanized mounting rails. Specify Rail Mount for this option.

Space Use and Setbacks

Wall Setbacks:
For Swerves set parallel to a wall:
Minimum: 24"
Recommended: 36"

For Swerves set perpendicular to a wall:
Minimum: 28"

Distance Between Racks:
Minimum: 24"
Recommended: 36"

Street Setbacks:
Minimum: 24"
Recommended: 36"

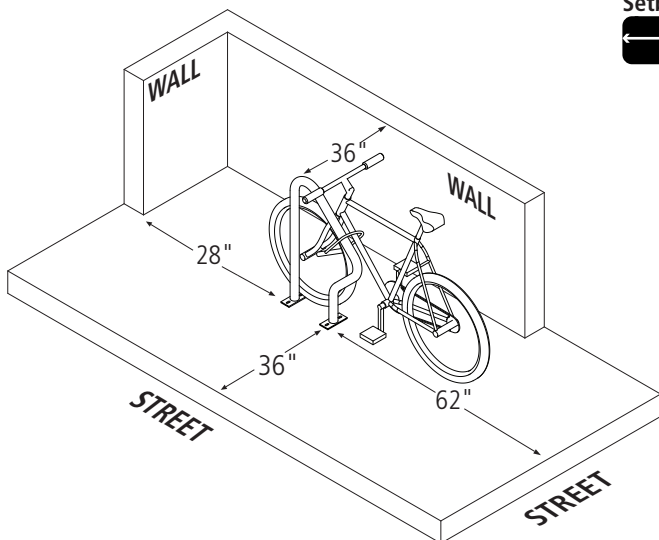

Tools Needed for Installation

- Tape Measure
- Marker or Pencil
- Masonry Drill Bit
- Drill (Hammer drill recommended)
- Hammer
- Wrench 9/16"
- Level

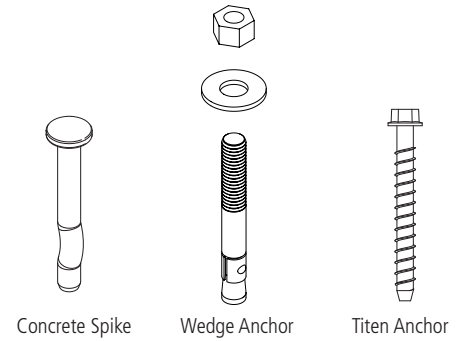

Standard Anchor Types

Recommended Base Materials:

Solid concrete is the best base material for installation. To ensure the proper anchors are shipped with your rack, ask your Dero Rack representative which anchor is appropriate for your application. Be sure nothing is underneath the base material that could be damaged by drilling.

Installation:

3/8" anchors are shipped with the rack. Place the rack in the desired location. Use a marker or pencil to outline the holes of the flange onto the base material. Drill the holes in accordance with the specifications shipped with the anchors. Make sure the holes are at least 3" away from any cracks in the base material. Use washers to level rack if necessary. Tap in anchors and follow your specific anchor instructions provided with the rack.

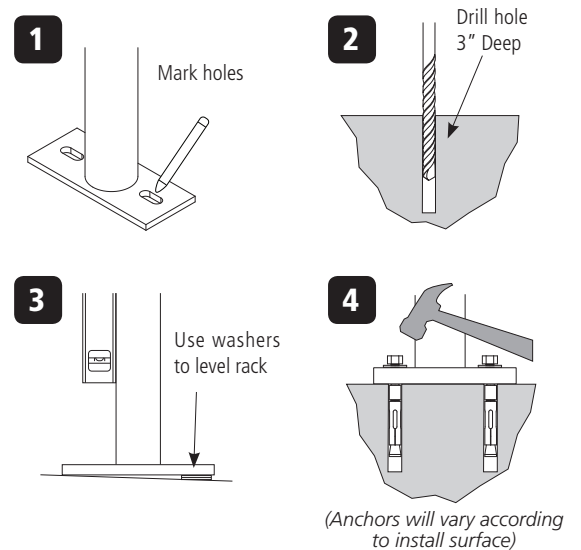

Tamper Resistant Fasteners

The concrete spike is a permanent anchor. The top of the wedge anchor can also be pounded sideways after installation so that it cannot be removed. Other tamper resistant fasteners are also available for purchase.

When using the special tamper resistant nuts, always set and first tighten the anchors. Once the rack is installed, replace two nuts from the bracket (opposite sides from each other) with the tamper resistant fastener. **DO NOT OVERTIGHTEN** the tamper resistant nut.

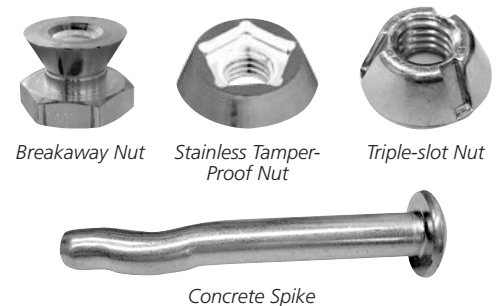

If you have any questions about installation or other features of the Swerve Rack, please call us toll free at 1-800-298-4915





Tools Needed for Installation

Level	Hole coring machine with 4" bit
Cement mixing tub	Access to water hose
Shovel	Materials to build brace (see "Install Tip" at bottom of page)
Trowel	

Installing into Existing Sidewalk

Core holes no less than 3" diameter (4" recommended) and 10" deep into sidewalk. Fill holes with Por-Rok or epoxy grout. Place Swerve Rack into holes, making sure the rack is level. 33"-36" of the Swerve Rack should remain above the surface. If the Swerve Rack is less than 33" high, it will not support the bike adequately. Make sure the rack is level and held in place until the grout has set.

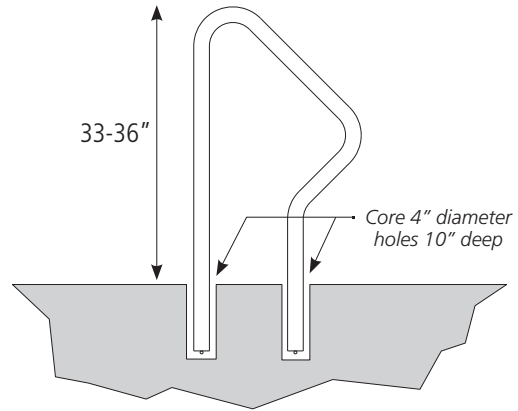

Installing Into a New Sidewalk:

Sleeve Method:

1 Place corrosion resistant sleeve (min. 3" inside diameter) in sand pour bed in exact location where rack will be installed. Make sure top of sleeve is at same level as desired finished concrete surface. Fill sleeve with sand to keep it in place and prevent it from filling with concrete.

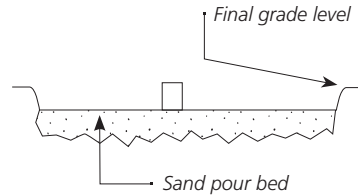

2 Pour concrete and allow to cure.

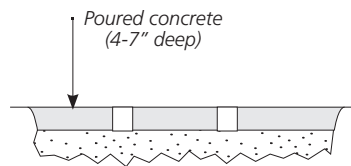

3 After appropriate cure time, dig out sand from sleeves and insert racks, making sure they are level and at the appropriate height. Pour in Por-Rok or epoxy grout and allow to set.

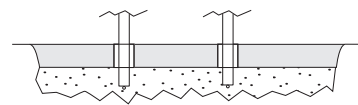

Note: Sleeve should have profile to keep it from coming loose from hardened concrete.

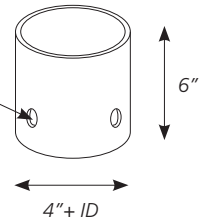

INSTALL TIP

An easy way to brace the Swerve Rack while the grout sets is to bolt two 1x4" boards together at one end and clamp them onto the legs of the Swerve Rack like a clothes pin.

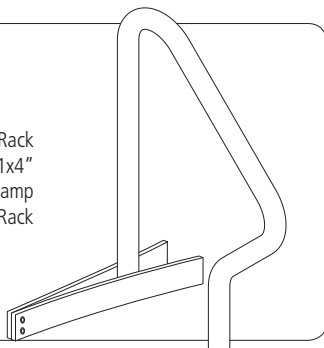



Rail Mounted Swerves

Rail mounted Swerve Racks are standard foot mounted Swerve Racks attached with bolts to a rail as in the diagram at left. Rail mounted racks provide more flexibility than other mounting options while providing the same degree of security.

Rail mounted Swerve Racks can be left freestanding, or they can be anchored to the ground using several anchors. This option allows for easier snow removal and sweeping. Installation of Rail mounted Swerves is also much less expensive than embedding the racks into the ground.

* Note: Though racks may be painted, the rails will remain with only a galvanized finish

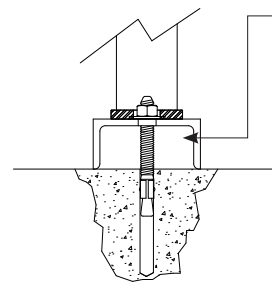
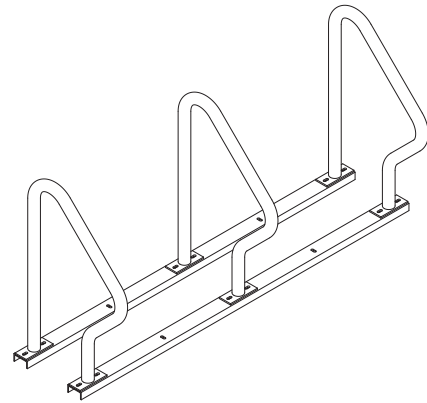

Anchor runs through rail into base install surface

Advantages to rail mounted Swerve Racks:

- Easier and inexpensive installation
- Can be left freestanding or anchored to the ground
- Easier to remove for sweeping and snow removal

Applications where Rail Mounted Swerves work best:

- Installation to pavers
- Asphalt Installations
- Ground, dirt, or mulch
- Situations where the rack needs to be moved occasionally

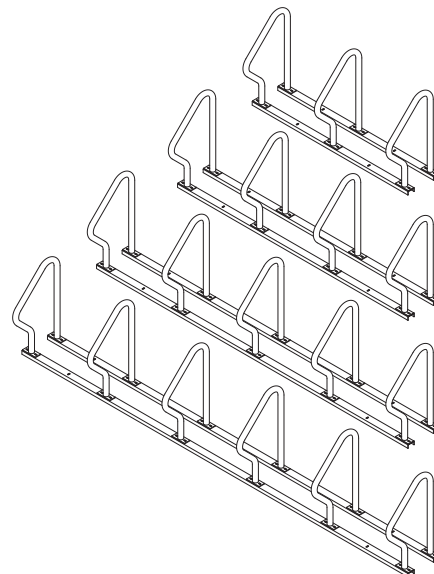

3 Swerves
76" Long
Parks 6 Bikes

4 Swerves
108" Long
Parks 8 Bikes

5 Swerves
146" Long
Parks 10 Bikes

6 Swerves
181" Long
Parks 12 Bikes



Tools Needed for Installation:

- 9/16" Socket set
- Two 4"x4"x28" (or larger) blocks
- 4 bolts, nuts and washers for every Swerve (included with rack). If using a tamper resistant nuts, install two tamper resistant nuts with each rack.

Installation Steps

- 1** Lay out the two channel beams where the rack will be placed. Place the two beams on top of the two blocks of wood so that the open part of the channel faces the ground.
- 2** Place Swerve Racks on beams so holes in rack flanges line up with beam slots.
- 3** Put bolts through Swerve Rack flange holes and beams so bolt head faces up. HAND tighten the nuts using new flange nuts.
- 4** Once nuts are on, tip assembled rack over and use a 9/16" socket to tighten nuts. Before fully tightening nuts, make sure the racks are straight on beams. If using tamper resistant nuts, use access tool to tighten nuts. Do not over-tighten the tamper resistant nuts. Tip rack upright.

Anchoring the Rails

To anchor the rails to concrete, place 3.75" wedge anchor through holes in the rail into the concrete. Secure with nut.

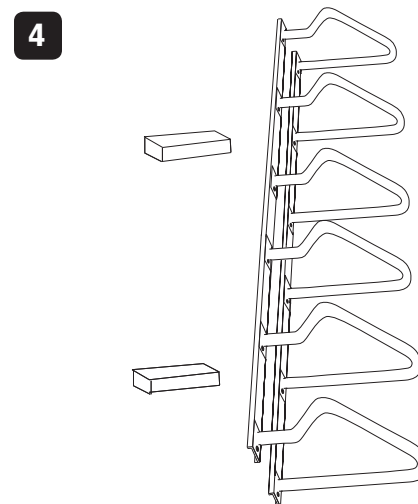
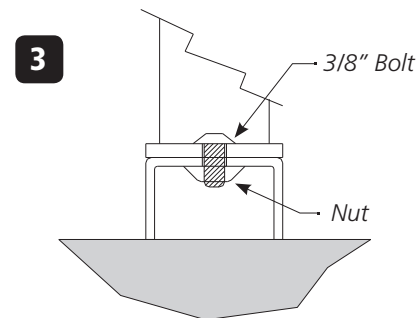
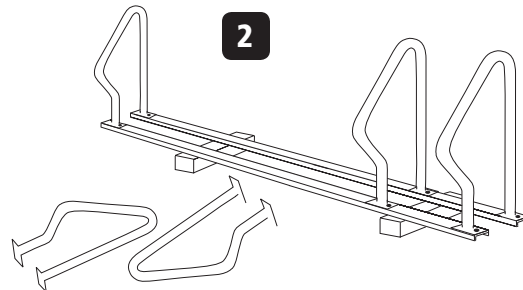
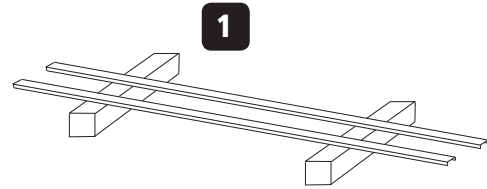
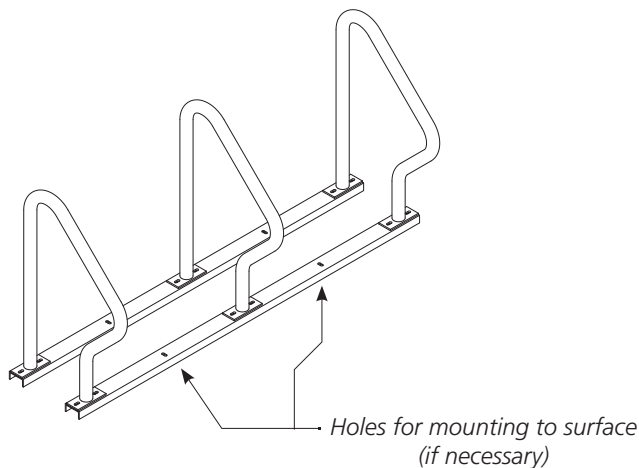
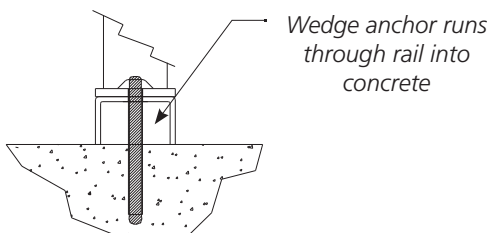



DERO **Hoop RACK**

- High security
- Superior bike support
- Freestanding rail mount available

The Dero Hoop Rack is a proven design that provides high security and easy bike parking. The Dero Hoop Rack uses thick pipe construction and the full radius of the bend makes the Dero Hoop an attractive and functional bike rack. The Dero Hoop Rack supports the bicycle at two points and allows for the wheel and frame to be secured using a u-style bike lock. Each Dero Hoop Rack parks two bikes.

Your Logo Here!



We can include your organization's logo in the center of a specially designed Dero Hoop Rack. Contact us for more details on this unique option.



DERO
A PLAYCORE Company

 www.dero.com  1.800.337.6729



 Printed on recycled paper



HOOP RACK

Specifications and Space Use

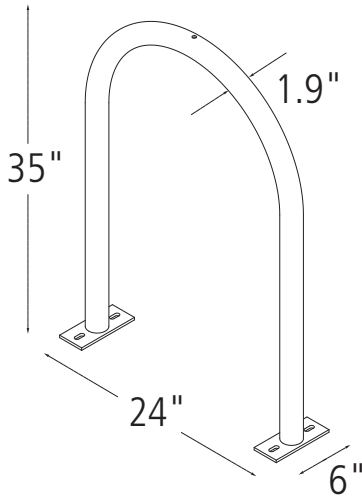

Product Dero Hoop Rack
As manufactured by Dero Bike Racks

Capacity 2 Bikes

Materials 1.5" schedule 40 pipe (1.9" OD)

Finishes An after fabrication hot dipped galvanized finish is our standard option. 250 TGIC powder coat colors, thermoplastic coating, PVC dip, and stainless steel finishes are also available as alternate options.

Our powder coat finish assures a high level of adhesion and durability by following these steps:

1. Sandblast
2. Epoxy primer electrostatically applied
3. Final thick TGIC polyester powder coat

Stainless Steel: 304 grade stainless steel material finished in either a high polished shine or a satin finish.

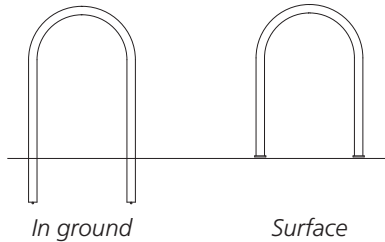

Installation Methods

In ground mount is embedded into concrete base. Specify in ground mount for this option.

Foot Mount has two 2.5"x6"x.25" feet with two anchors per foot. Specify foot mount for this option.

Rail Mounted Hoops are bolted to two parallel rails which can be left freestanding or anchored to the ground. Rails are heavy duty 3"x1.4"x3/16" thick galvanized mounting rails. Specify rail mount for this option.



Space Use and Setbacks

Wall Setbacks:
For racks set parallel to a wall:
Minimum: 24"
Recommended: 36"

For racks set perpendicular to a wall:
Minimum: 28"
Recommended: 42"

Distance Between Racks:
Minimum: 24"
Recommended: 36"

Street Setbacks:
Minimum: 24"
Recommended: 36"

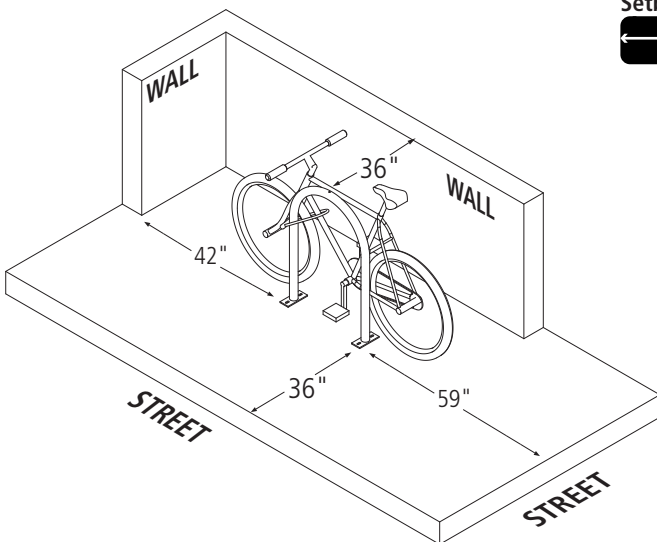

DERO
A PLAYCORE Company



www.dero.com



1.800.337.6729



Tools Needed for Installation

- Tape Measure
- Marker or Pencil
- Masonry Drill Bit
- Drill (Hammer drill recommended)
- Hammer
- Wrench 9/16"
- Level

Recommended Base Materials:

Solid concrete is the best base material for installation. To ensure the proper anchors are shipped with your rack, ask your Dero Rack representative which anchor is appropriate for your application. Be sure nothing is underneath the base material that could be damaged by drilling.

Installation:

3/8" anchors are shipped with the rack. Place the rack in the desired location. Use a marker or pencil to outline the holes of the flange onto the base material. Drill the holes in accordance with the specifications shipped with the anchors. Make sure the holes are at least 3" away from any cracks in the base material. Use washers to level rack if necessary. Tap in anchors and follow your specific anchor instructions provided with the rack.

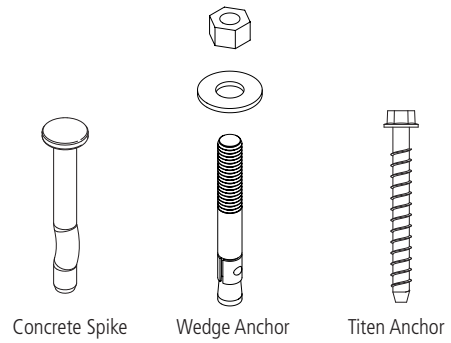

Standard Anchor Types

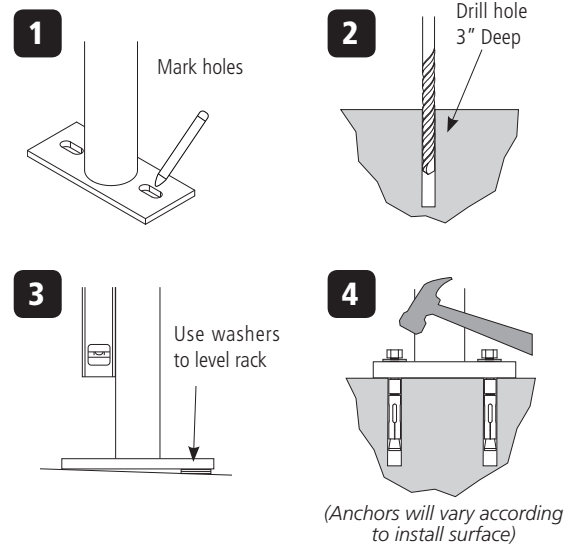

Tamper Resistant Fasteners

The concrete spike is a permanent anchor. The top of the wedge anchor can also be pounded sideways after installation so that it cannot be removed. Other tamper resistant fasteners are also available for purchase.

When using the special tamper resistant nuts, always set and first tighten the anchors. Once the rack is installed, replace two nuts from the bracket (opposite sides from each other) with the tamper resistant fastener. DO NOT OVERTIGHTEN the tamper resistant nut.

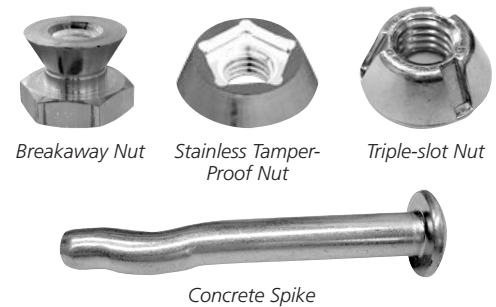

If you have any questions about installation or other features of the Hoop Rack, please call us toll free at 1-800-298-4915





Tools Needed for Installation

Level	Hole coring machine with 4" bit
Cement mixing tub	Access to water hose
Shovel	Materials to build brace (see "Install Tip" at bottom of page)
Trowel	

Installing into Existing Sidewalk

Core holes no less than 3" diameter (4" recommended) and 10" deep into sidewalk. Fill holes with Por-Rok or epoxy grout. Place Hoop Rack into holes, making sure the rack is level. 33"-36" of the Hoop Rack should remain above the surface. If the Hoop Rack is less than 33" high, it will not support the bike adequately. Make sure the rack is level and held in place until the grout has set.

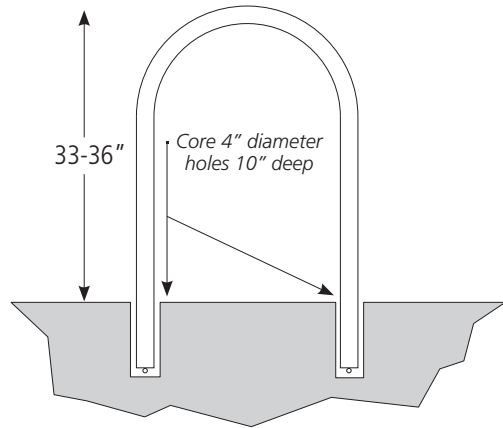

Installing Into a New Sidewalk:

Sleeve Method:

1 Place corrosion resistant sleeve (min. 4" inside diameter) in sand pour bed in exact location where rack will be installed. Make sure top of sleeve is at same level as desired finished concrete surface. Fill sleeve with sand to keep it in place and prevent it from filling with concrete.

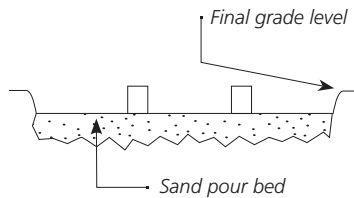

2 Pour concrete and allow to cure.

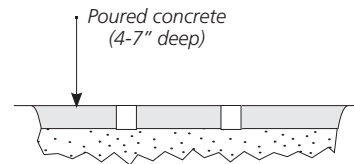

3 After appropriate cure time, dig out sand from sleeves and insert racks, making sure they are level and at the appropriate height. Pour in Por-Rok or epoxy grout and allow to set.

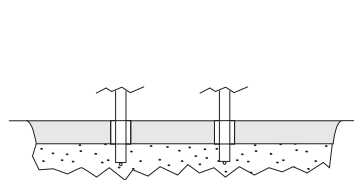

Note: Sleeve should have profile to keep it from coming loose from hardened concrete.

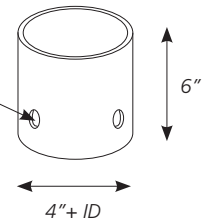

INSTALL TIP

An easy way to brace the Hoop Rack while the grout sets is to bolt two 1x4" boards together at one end and clamp them onto the legs of the Hoop Rack like a clothes pin.

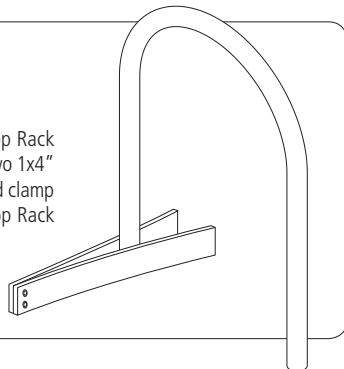



RAIL MOUNTED HOOPS

Rail mounted Hoop Racks are standard foot mounted Hoop Racks attached with bolts to a rail as in the diagram at left. Rail mounted racks provide more flexibility than other mounting options while providing the same degree of security.

Rail mounted Hoop Racks can be left freestanding, or they can be anchored to the ground using several anchors. This option allows for easier snow removal and sweeping. Installation of Rail mounted Hoops is also much less expensive than embedding the racks into the ground.

* Note: Though racks may be painted, the rails will remain with only a galvanized finish

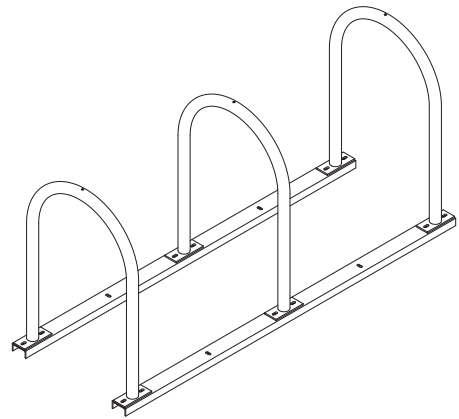

Advantages to rail mounted Hoop Racks:

- Easier and inexpensive installation
- Can be left freestanding or anchored to the ground
- Easier to remove for sweeping and snow removal

Applications where Rail Mounted Hoops work best:

- Installation to pavers
- Asphalt Installations
- Ground, dirt, or mulch
- Situations where the rack needs to be moved occasionally

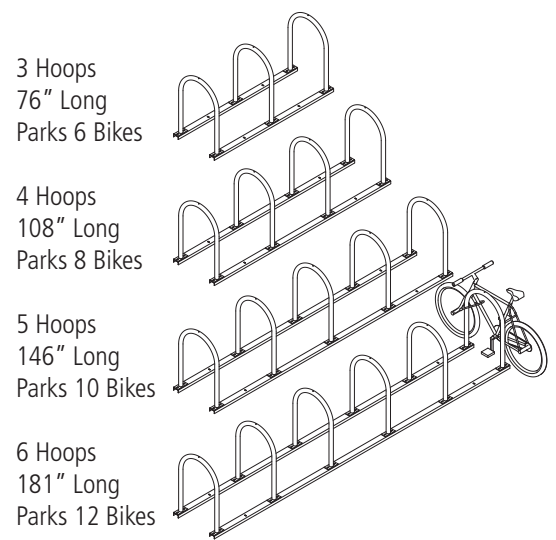
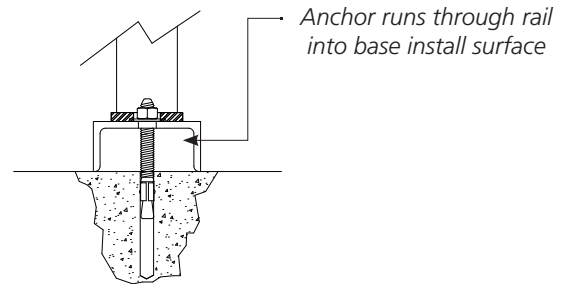



Tools Needed for Installation:

- 9/16" Socket set
- Two 4"x4"x28" (or larger) blocks
- 4 bolts, nuts and washers for every Hoop (included with rack). If using a tamper resistant nuts, install two tamper resistant nuts with each Hoop.

Installation Steps

- 1** Lay out the two channel beams where the rack will be placed. Place the two beams on top of the two blocks of wood so that the open part of the channel faces the ground.
- 2** Place Hoop Racks on beams so holes in rack flanges line up with beam slots
- 3** Put bolts through Hoop Rack flange holes and beams so bolt head faces up. HAND tighten the nuts using new flange nuts.
- 4** Once nuts are on, tip assembled rack over and use a 9/16" socket to tighten nuts. Before fully tightening nuts, make sure the racks are straight on beams. If using tamper resistant nuts, use access tool to tighten nuts. Do not overtighten the tamper resistant nuts. Tip rack upright.

Anchoring the Rails

To anchor the rails to concrete, place 3.75" wedge anchor through holes in the rail into the concrete. Secure with nut.

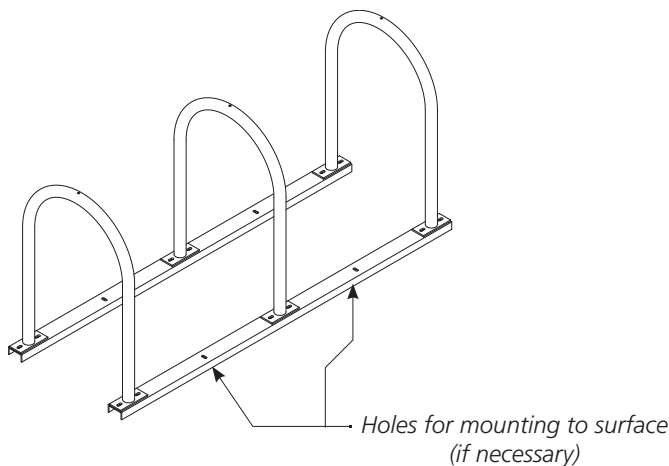
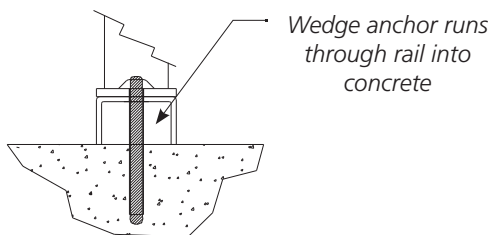
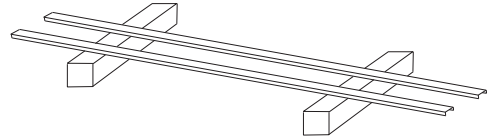
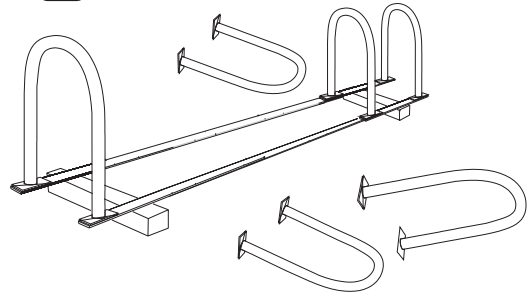
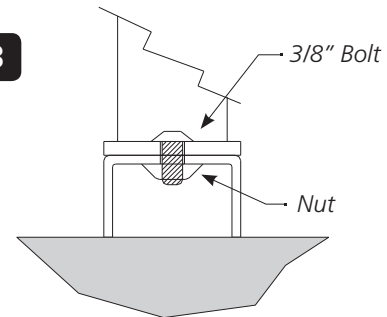
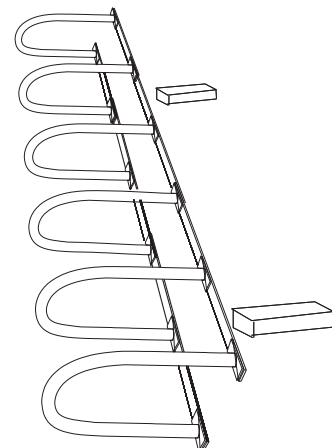
**1****2****3****4**



DERO **H**OOB RACK HEAVY DUTY

- Easily recognizable, usable bike parking
- Meets APBP guidelines
- Added strength and security

Like its lighter sibling, the Dero Hoop Rack Heavy Duty provides great security and simple, straight-forward bike parking. The Dero Hoop Rack HD meets APBP guidelines for u-lock compatibility and two points of support for the bike. For added security and peace of mind, the Dero Hoop Rack HD uses a larger, thicker pipe.



Your Logo Here!



We can include your organization's logo in the center of a specially designed Dero Hoop Rack Heavy Duty. Contact us for more details on this unique option.

 www.dero.com  1.800.337.6729



 Printed on recycled paper

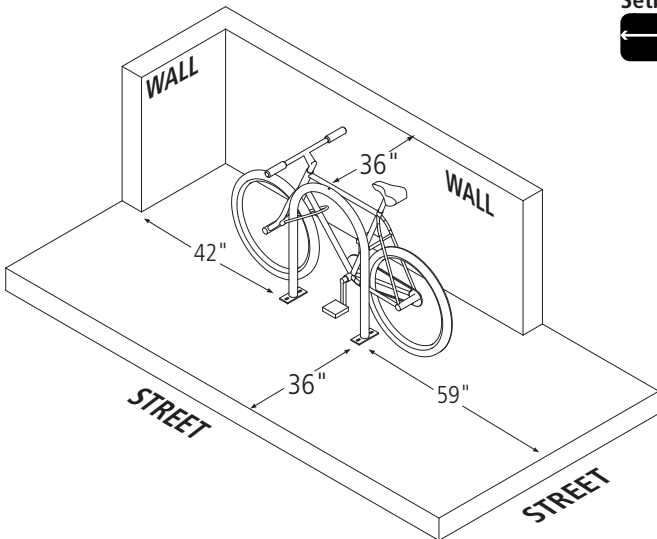
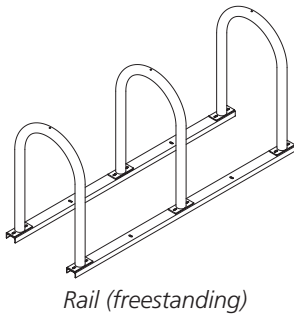
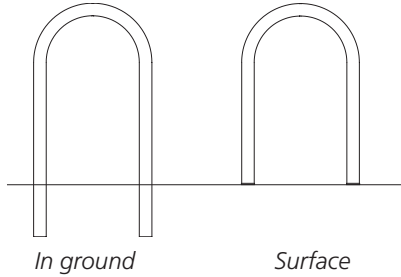
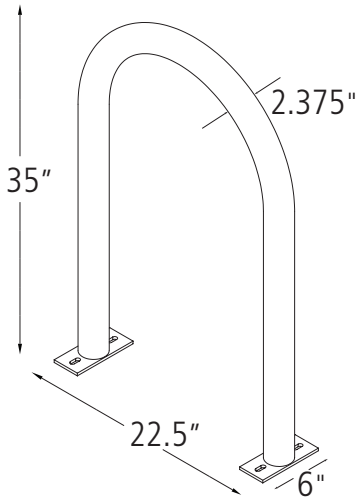

Product Dero Hoop Rack Heavy Duty
As manufactured by Dero Bike Racks

Capacity 2 Bikes

Materials 2" schedule 40 pipe (2.375" OD)

Finishes An after fabrication hot dipped galvanized finish is our standard option. 250 TGIC powder coat colors, thermoplastic coating, PVC dip, and stainless steel finishes are also available as alternate options.

Our powder coat finish assures a high level of adhesion and durability by following these steps:

1. Sandblast
2. Epoxy primer electrostatically applied
3. Final thick TGIC polyester powder coat

Stainless Steel: 304 grade stainless steel material finished in either a high polished shine or a satin finish.

Installation Methods

In ground mount is embedded into concrete base. Specify in ground mount for this option.

Foot Mount has two 2.5" x 6" x .25" feet with two anchors per foot. Specify foot mount for this option.

Rail Mounted Hoops are bolted to two parallel rails which can be left freestanding or anchored to the ground. Rails are heavy duty 3" x 1.4" x 3/16" thick galvanized mounting rails. Specify rail mount for this option.

Space Use and Setbacks

Wall Setbacks:

For racks set parallel to a wall:
Minimum: 24"
Recommended: 36"

For racks set perpendicular to a wall:

Minimum: 28"
Recommended: 42"

Distance Between Racks:

Minimum: 24"
Recommended: 36"

Street Setbacks:

Minimum: 24"
Recommended: 36"





Tools Needed for Installation

- Tape Measure
- Marker or Pencil
- Masonry Drill Bit
- Drill (Hammer drill recommended)
- Hammer
- Wrench 9/16"
- Level

Recommended Base Materials:

Solid concrete is the best base material for installation. To ensure the proper anchors are shipped with your rack, ask your Dero Rack representative which anchor is appropriate for your application. Be sure nothing is underneath the base material that could be damaged by drilling.

Installation:

3/8" anchors are shipped with the rack. Place the rack in the desired location. Use a marker or pencil to outline the holes of the flange onto the base material. Drill the holes in accordance with the specifications shipped with the anchors. Make sure the holes are at least 3" away from any cracks in the base material. Use washers to level rack if necessary. Tap in anchors and follow your specific anchor instructions provided with the rack.

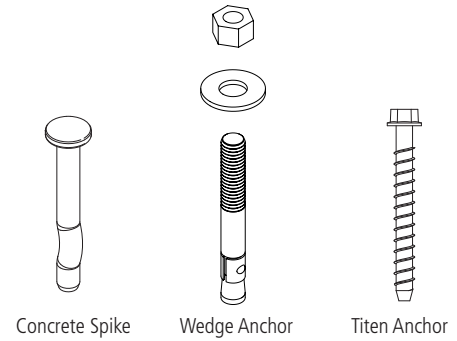

Standard Anchor Types

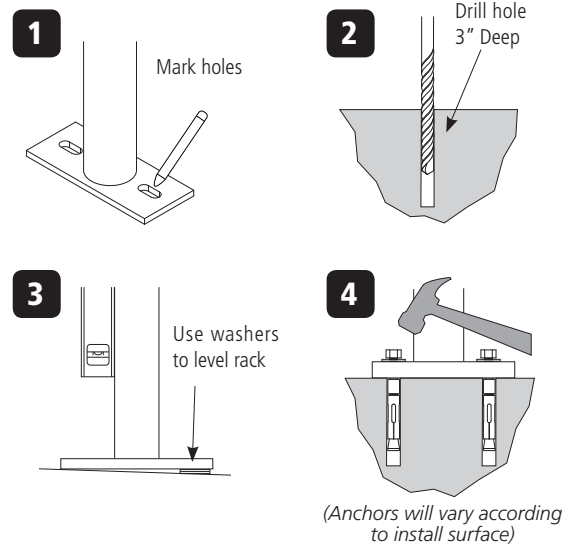

Tamper Resistant Fasteners

The concrete spike is a permanent anchor. The top of the wedge anchor can also be pounded sideways after installation so that it cannot be removed. Other tamper resistant fasteners are also available for purchase.

When using the special tamper resistant nuts, always set and first tighten the anchors. Once the rack is installed, replace two nuts from the bracket (opposite sides from each other) with the tamper resistant fastener. DO NOT OVERTIGHTEN the tamper resistant nut.

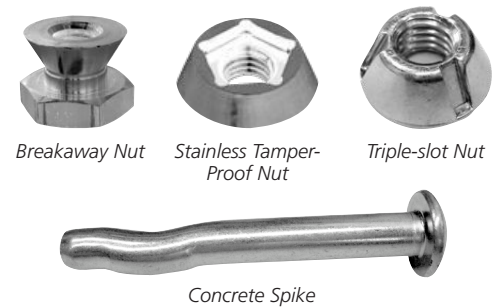

If you have any questions about installation or other features of the Hoop Rack Heavy Duty, please call us toll free at 1-800-298-4915





Tools Needed for Installation

Level	Hole coring machine with 4" bit
Cement mixing tub	Access to water hose
Shovel	Materials to build brace (see "Install Tip" at bottom of page)
Trowel	

Installing into Existing Sidewalk

Core holes no less than 3" diameter (4" recommended) and 10" deep into sidewalk. Fill holes with Por-Rok or epoxy grout. Place Hoop Rack Heavy Duty into holes, making sure the rack is level. 33"-36" of the Hoop Rack Heavy Duty should remain above the surface. If the Hoop Rack Heavy Duty is less than 33" high, it will not support the bike adequately. Make sure the rack is level and held in place until the grout has set.

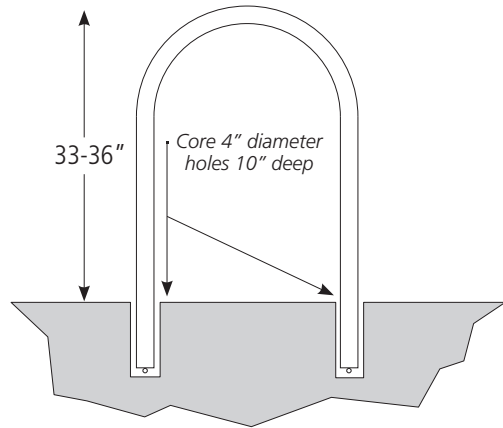

Installing Into a New Sidewalk:

1 Place corrosion resistant sleeve (min. 4" inside diameter) in sand pour bed in exact location where rack will be installed. Make sure top of sleeve is at same level as desired finished concrete surface. Fill sleeve with sand to keep it in place and prevent it from filling with concrete.

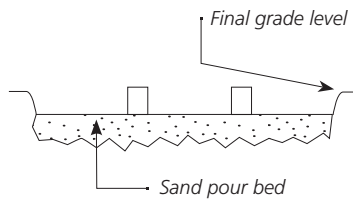

2 Pour concrete and allow to cure.

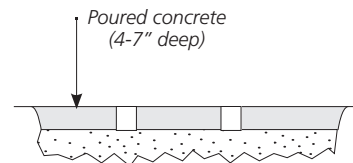

3 After appropriate cure time, dig out sand from sleeves and insert racks, making sure they are level and at the appropriate height. Pour in Por-Rok or epoxy grout and allow to set.

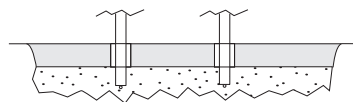

Note: Sleeve should have profile to keep it from coming loose from hardened concrete.

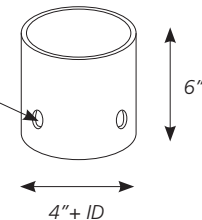

INSTALL TIP

An easy way to brace the Hoop Rack Heavy Duty while the grout sets is to bolt two 1x4" boards together at one end and clamp them onto the legs of the Hoop Rack Heavy Duty like a clothes pin.

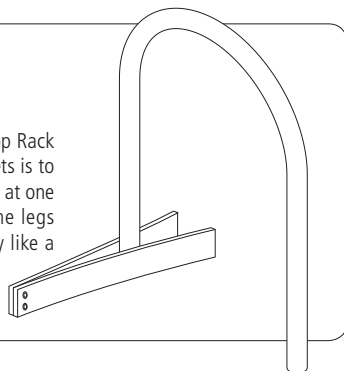



RAIL MOUNTED HOOP HDs

Rail mounted Hoop Rack Heavy Dutys are standard foot mounted Hoop Rack Heavy Dutys attached with bolts to a rail as in the diagram at left. Rail mounted racks provide more flexibility than other mounting options while providing the same degree of security.

Rail mounted Hoop Rack Heavy Dutys can be left freestanding, or they can be anchored to the ground using several anchors. This option allows for easier snow removal and sweeping. Installation of Rail mounted Hoops is also much less expensive than embedding the racks into the ground.

* Note: Though racks may be painted, the rails will remain with only a galvanized finish

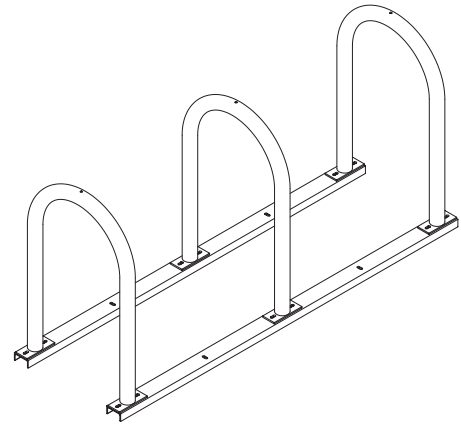

Advantages to rail mounted Hoop Rack HDs:

- Easier and inexpensive installation
- Can be left freestanding or anchored to the ground
- Easier to remove for sweeping and snow removal

Applications where Rail Mounted Hoop HDs work best:

- Installation to pavers
- Asphalt Installations
- Ground, dirt, or mulch
- Situations where the rack needs to be moved occasionally

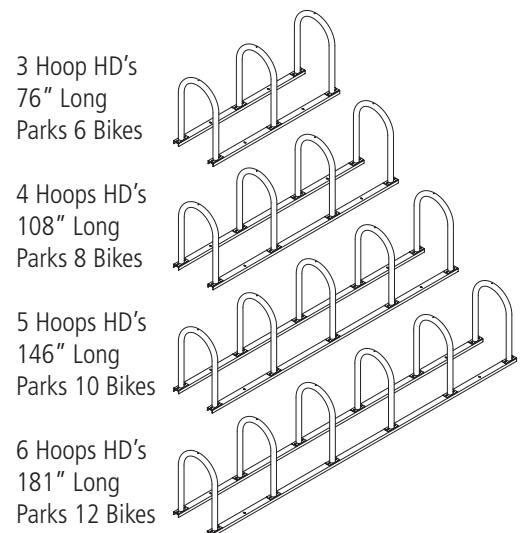
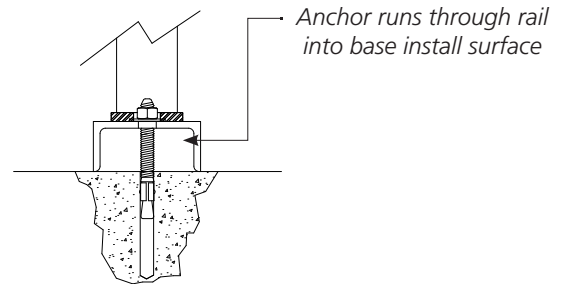



Tools Needed for Installation:

- 9/16" Socket set
- Two 4"x4"x28" (or larger) blocks
- 4 bolts, nuts and washers for every Hoop (included with rack). If using a tamper resistant nuts, install two tamper resistant nuts with each Hoop.

Installation Steps

- 1** Lay out the two channel beams where the rack will be placed. Place the two beams on top of the two blocks of wood so that the open part of the channel faces the ground.
- 2** Place Hoop Rack Heavy Dutys on beams so holes in rack flanges line up with beam slots.
- 3** Put bolts through Hoop Rack Heavy Duty flange holes and beams so bolt head faces up. HAND tighten the nuts using new flange nuts.
- 4** Once nuts are on, tip assembled rack over and use a 9/16" socket to tighten nuts. Before fully tightening nuts, make sure the racks are straight on beams. If using tamper resistant nuts, use access tool to tighten nuts. Do not overtighten the tamper resistant nuts. Tip rack upright.

Anchoring the Rails

To anchor the rails to concrete, place 3.75" wedge anchor through holes in the rail into the concrete. Secure with nut.

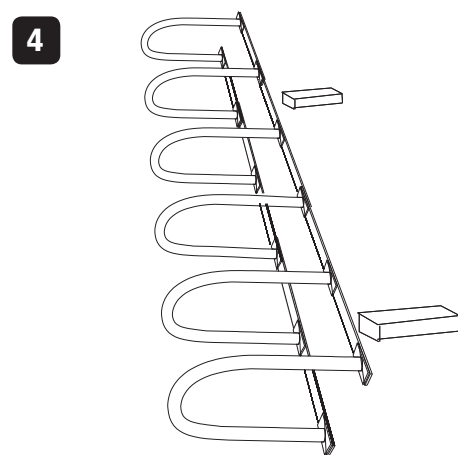
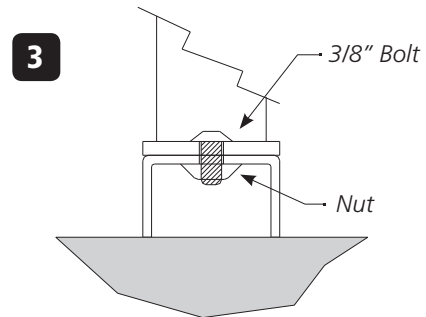
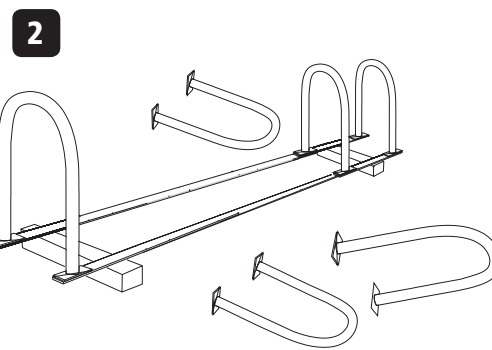
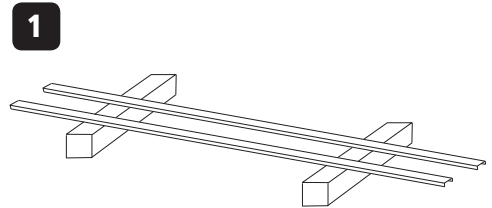
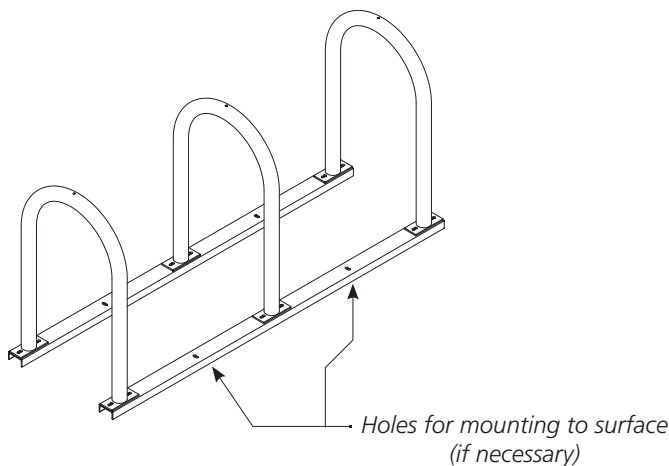
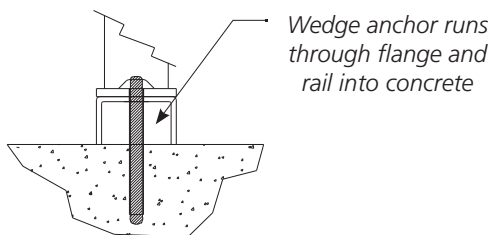



DERO

BIKE HITCH

- High security
- great for sidewalk placement
- one unit parks two bikes

The Dero Bike Hitch is an attractive and space efficient bike rack. The Dero Bike Hitch was specifically designed for sidewalks and other narrow space applications. The rack's design restricts bikes to parking parallel with the rack so bikes won't protrude out into the sidewalk or street.

Your Logo Here!



We can include your organization's logo in the center of a specially designed Dero Bike Hitch. Contact us for more details on this unique option.



DERO
A PLAYCORE Company

 www.dero.com  1.800.337.6729

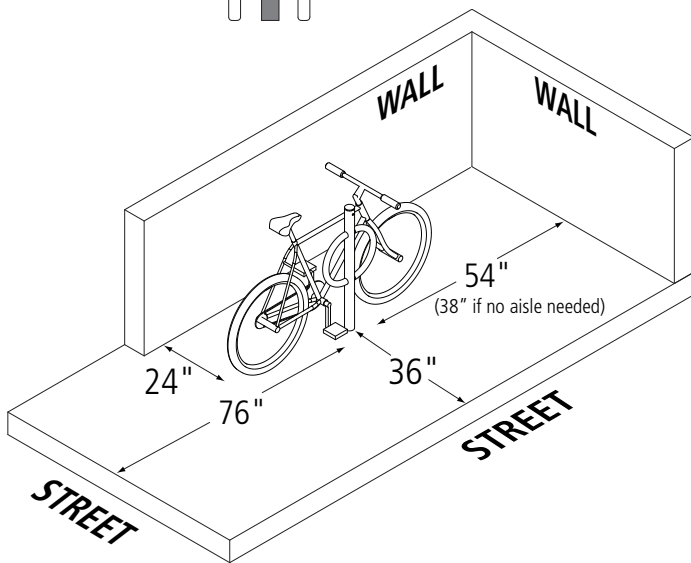
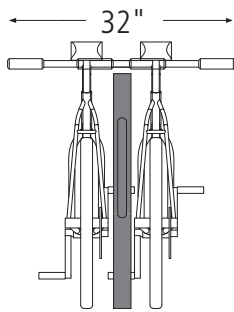
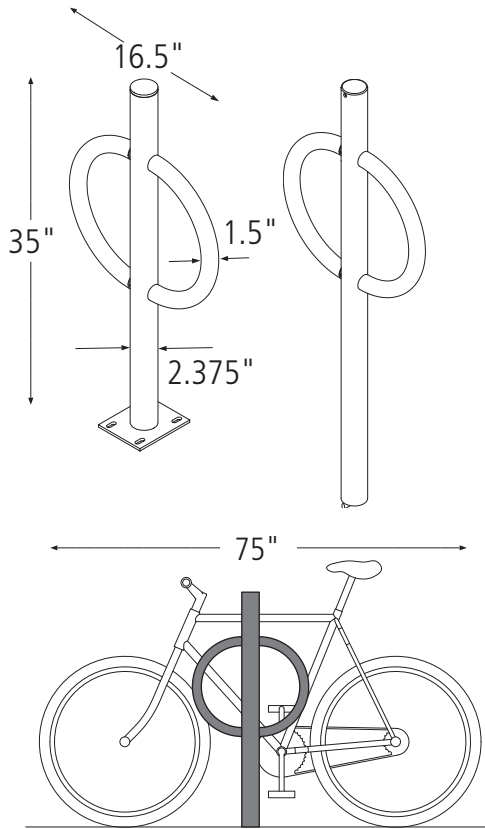

Printed on recycled paper

Product

Dero Bike Hitch
As manufactured by Dero Bike Racks

Capacity

2 Bikes

Materials

Centerbeam: 2" schedule 40 pipe (2.375" OD)
Ring: 1.5" OD 11 gauge tube

Finishes

An after fabrication hot dipped galvanized finish is our standard option. 250 TGIC powder coat colors, thermoplastic coating, PVC dip, and stainless steel finishes are also available as alternate options.

Our powder coat finish assures a high level of adhesion and durability by following these steps:

1. Sandblast
2. Epoxy primer electrostatically applied
3. Final thick TGIC polyester powder coat

Stainless Steel: 304 grade stainless steel material finished in either a high polished shine or a satin finish.

Installation Methods

In-ground mount is embedded into concrete base.
Surface mount has one 5" x 6" foot which is anchored to the ground with four anchors (included with rack).

Space Use and Setbacks

Wall Setbacks:

For racks set parallel to a wall:
Minimum: 12"
Recommended: 24"

For racks set perpendicular to a wall:

Minimum: 35" (centerline measurement)
Recommended: 38" (54" if aisle is needed between bike and wall)

Distance Between Racks:

For racks set facing one another:
Minimum: 24"
Recommended: 38"

For racks set end to end:

Minimum: 90"
Recommended: 111"

Street Setbacks:

Minimum: 36"





Tools Needed for Installation

- Tape Measure
- Marker or Pencil
- Masonry Drill Bit
- Drill (Hammer drill recommended)
- Hammer
- Wrench 9/16"
- Level
- Washers (for leveling if necessary)

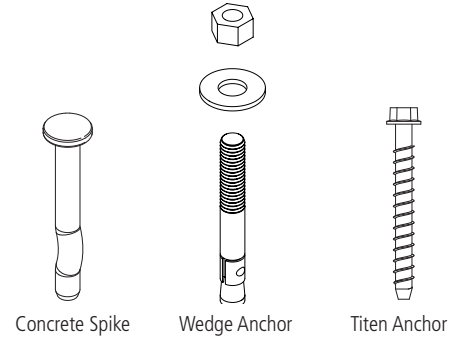

Standard Anchor Types

Recommended Base Materials:

Solid concrete is the best base material for installation. Ask your Dero Rack representative which anchor is appropriate for your application to ensure the proper anchors are shipped with your rack. Be sure nothing is underneath the base material that could be damaged by drilling.

Installation:

3/8" anchors are shipped with the rack. Place the rack in the desired location. Use a marker or pencil to outline the holes of the flange onto the base material. Drill the holes in accordance with the specifications shipped with the anchors. Make sure the holes are at least 6" away from any cracks in the base material.

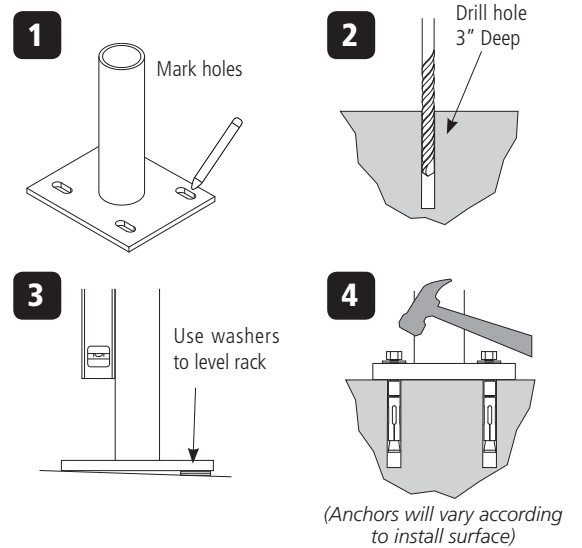

Tamper Resistant Fasteners

The concrete spike is a permanent anchor. The top of the wedge anchor can also be pounded sideways after installation so that it cannot be removed. Other tamper resistant fasteners are also available for purchase.

When using the special tamper resistant nuts, always set and first tighten the anchors. Once the rack is installed, replace two nuts from the bracket (opposite sides from each other) with the tamper resistant fastener. DO NOT OVERTIGHTEN the tamper resistant nut.

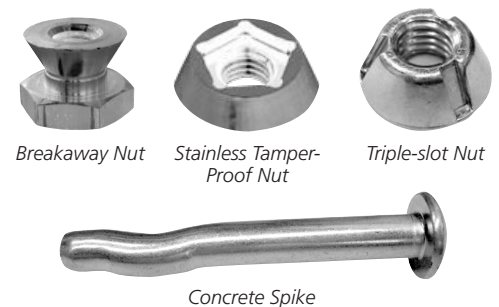

If you have any questions about installation or other features of the Bike Hitch, please call us toll free at 1-800-298-4915





Tools needed for installation

Level	Hole coring machine with 4" bit
Cement mixing tub	Access to water hose
Shovel	Materials to build brace (see "Install Tip" at bottom of page)
Trowel	

Installing into Existing Sidewalk

Core holes no less than 3" diameter (4" recommended) and 10" deep into sidewalk. Place Bike Hitch into hole making sure the rack is level. Fill hole with Por-Rok or epoxy grout. 34-36" of the Bike Hitch should remain above the surface. Make sure Hitch is level and held in place until the grout has completely set.

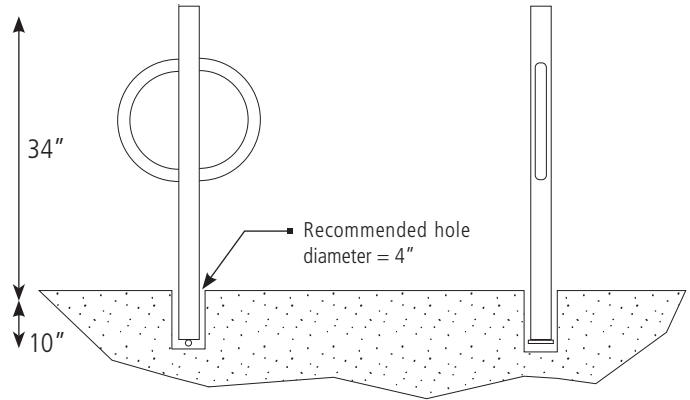

Installing Into a New Sidewalk:

1 Place corrosion resistant sleeve (min. 3" inside diameter) in sand pour bed in exact location where rack will be installed. Make sure top of sleeve is at same level as desired finished concrete surface. Fill sleeve with sand to keep it in place and prevent it from filling with concrete.

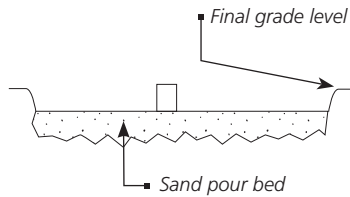

2 Pour concrete and allow to cure.

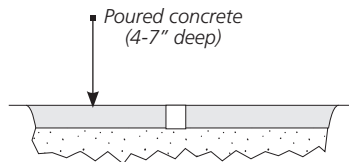

3 After appropriate cure time, dig out sand from sleeves and insert racks, making sure they are level and at the appropriate height. Pour in Por-Rok or epoxy grout and allow to set.

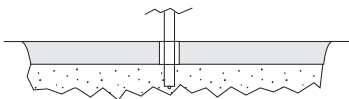

Note: Sleeve should have profile to keep it from coming loose from hardened concrete.

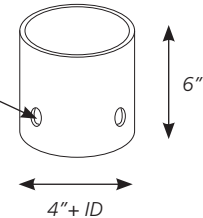

INSTALL TIP

An easy way to brace the Bike Hitch while the grout sets is to bolt two 1x4" boards together at one end and clamp them onto the legs of the Bike Hitch like a clothes pin.

