

---

# Assembly Instructions

## Lock-It 10 Bike Rack

7ZT7075

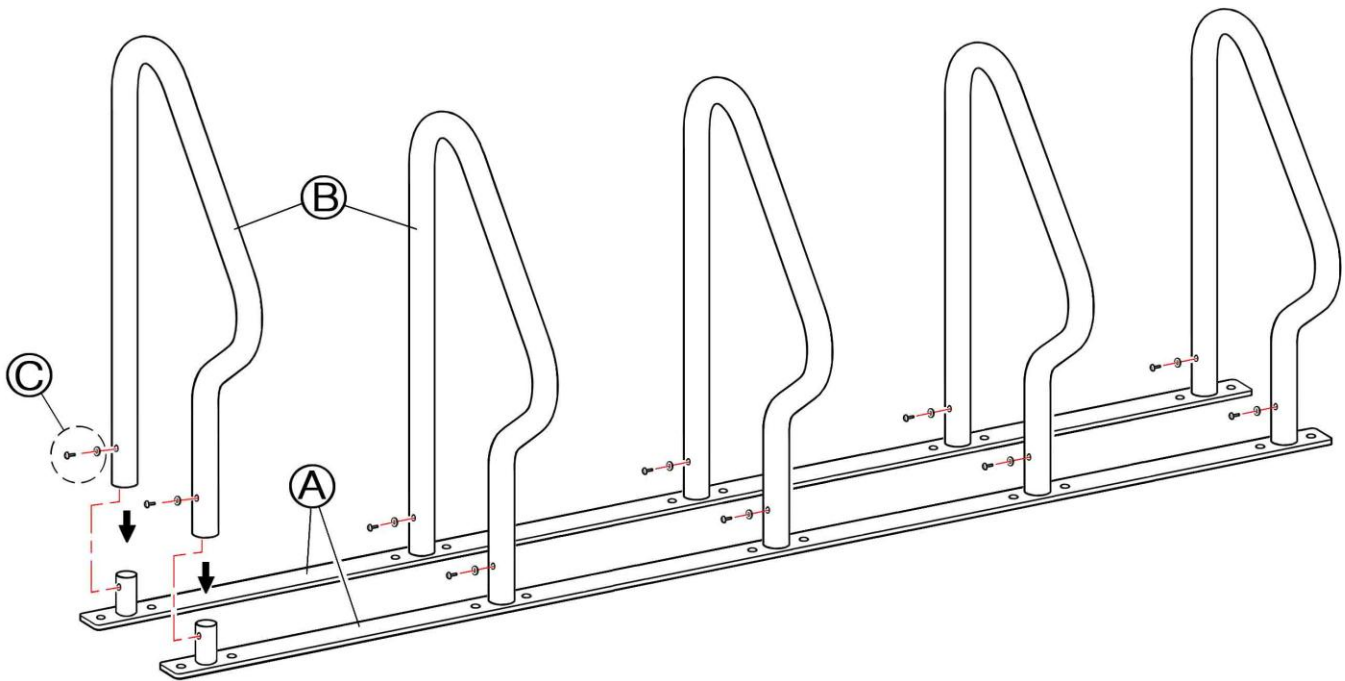

- Step 1:** Locate and position the bike rack frame onto a hard clean surface with appropriate space to accommodate Ten bikes. Five on each side.
- Step 2:** Make sure that all safety precautions are taken and the appropriate safety glasses, gloves and shoes are in use.
- Step 3:** Position and attach the five bike mounting assemblies (B) onto mounting plates (A), one at a time using the screws (C) provided. Keep the screws loose and adjust to square up the position of frames and mounting plates, tighten the screws.
- Step 4:** Position the bike rack where it will mount and mark the bolts spots with a marking pen using the bolt holes in the mounting plates (A) as a template.
- Step 5:** Set the rack aside and drill the mounting holes using a carbide tipped bit.
- Step 6:** Reposition the bike rack mounting plates (A) and secure them to the surface with the bolts. Re-tighten screws if needed.

**Tools required:** (1) Power drill with carbide tipped masonry drill bit (1) Marking pen, Hammer and center punch (1) Socket wrench and ratchet